

# INTERNATIONAL STANDARD

# ISO 4759-1

Second edition  
2000-11-15

---

## Tolerances for fasteners —

### Part 1: Bolts, screws, studs and nuts — Product grades A, B and C

*Tolérances des éléments de fixation —*

*Partie 1: Vis, goujons et écrous — Grades A, B et C*



Reference number  
ISO 4759-1:2000(E)

© ISO 2000

**PDF disclaimer**

This PDF file may contain embedded typefaces. In accordance with Adobe's licensing policy, this file may be printed or viewed but shall not be edited unless the typefaces which are embedded are licensed to and installed on the computer performing the editing. In downloading this file, parties accept therein the responsibility of not infringing Adobe's licensing policy. The ISO Central Secretariat accepts no liability in this area.

Adobe is a trademark of Adobe Systems Incorporated.

Detail of the software products used to create this PDF file can be found in the General Info relative to the file; the PDF-creation parameters were optimized for printing. Every care has been taken to ensure that the file is suitable for use by ISO member bodies. In the unlikely event that a problem relating to it is found, please inform the Central Secretariat at the address given below.

© ISO 2000

All rights reserved. Unless otherwise specified, no part of this publication may be reproduced or utilized in any form or by any means, electronic or mechanical including photocopying and microfilm, without permission in writing from either ISO at the address below or ISO's member body in the country of the requester.

ISO copyright office  
Case postale 56 CH-1211 Geneva 20

Tel. +41 22 749 0111

Fax +41 22 749 0947

E-mail [copyright@iso.ch](mailto:copyright@iso.ch)

Web [www.iso.ch](http://www.iso.ch)

Printed in Switzerland

## Contents

	Page
<b>Foreword</b> .....	<b>iv</b>
<b>1 Scope</b> .....	<b>1</b>
<b>2 Normative references</b> .....	<b>2</b>
<b>3 Tolerances for metric bolts, screws and studs</b> .....	<b>3</b>
<b>4 Tolerances for metric nuts</b> .....	<b>25</b>
<b>5 Tolerances for tapping screws</b> .....	<b>36</b>
<b>Annex A (informative) Tolerances</b> .....	<b>44</b>
<b>Annex B (informative) Examples of dimensioned and toleranced fasteners</b> .....	<b>46</b>
<b>Annex C (informative) Examples of gauges and other measuring devices</b> .....	<b>49</b>

## Foreword

ISO (the International Organization for Standardization) is a worldwide federation of national standards bodies (ISO member bodies). The work of preparing International Standards is normally carried out through ISO technical committees. Each member body interested in a subject for which a technical committee has been established has the right to be represented on that committee. International organizations, governmental and non-governmental, in liaison with ISO, also take part in the work. ISO collaborates closely with the International Electrotechnical Commission (IEC) on all matters of electrotechnical standardization.

International Standards are drafted in accordance with the rules given in the ISO/IEC Directives, Part 3.

Draft International Standards adopted by the technical committees are circulated to the member bodies for voting. Publication as an International Standard requires approval by at least 75% of the member bodies casting a vote.

Attention is drawn to the possibility that some of the elements of this part of ISO 4759 may be the subject of patent rights. ISO shall not be held responsible for identifying any or all such patent rights.

International Standard ISO 4759-1 was prepared by Technical Committee ISO/TC2, Fasteners, Subcommittee SC7, Reference Standards for fasteners (mainly covering terminology, dimensioning, sizes and tolerancing).

This second edition cancels and replaces the first edition (ISO 4759-1:1978), which has been technically revised.

ISO 4759 consists of the following parts, under the general title Tolerances for fasteners:

—Part 1: Bolts, screws, studs and nuts —Product grades A, B and C

—Part 3: Plain washers for bolts, screws and nuts —Product grades A and C

Annexes A to C of this part of ISO 4759 are for information only.



# Tolerances for fasteners —

## Part 1: Bolts,screws,studs and nuts —Product grades A,B and C

### 1 Scope

This part of ISO 4759 specifies a selection of tolerances for bolts,screws,studs and nuts with ISO metric threads and with product grades A,B and C and for tapping screws with product grade A.

NOTE The product grades refer to the size of the tolerances where grade A is the most precise and grade C is the least precise.

The tolerances,except tolerances for threads,are selected from the system of limits and fits specified in ISO 286-1 and ISO 286-2.The tolerances for metric threads are taken from the series of tolerance classes specified in ISO 965-3.The tolerances for tapping screw threads are covered in ISO 1478.

The tolerances of form and position are specified and indicated in accordance with ISO 1101,ISO 8015 and ISO 2692.

The tolerances specified in this part of ISO 4759 apply to fasteners prior to coating unless otherwise specified.See also ISO 4042.

Deviations from the tolerances specified in this part of ISO 4759 are only permitted in product standards where there are valid technical reasons.In cases where there is a difference between the tolerance requirements in this part of ISO 4759 and the product standard,the product standard takes precedence.

It is recommended that these tolerances also be used for non-standard fasteners.

Dimensions and tolerances given in this part of ISO 4759 are in millimetres.

## 2 Normative references

The following normative documents contain provisions which, through reference in this text, constitute provisions of this part of ISO 4759. For dated references, subsequent amendments to, or revisions of, any of these publications do not apply. However, parties to agreements based on this part of ISO 4759 are encouraged to investigate the possibility of applying the most recent editions of the normative documents indicated below. For undated references, the latest edition of the normative document referred to applies. Members of ISO and IEC maintain registers of currently valid International Standards.

*ISO 225:1983, Fasteners —Bolts, screws, studs and nuts —Symbols and designation of dimensions.*

*ISO 286-1:1988, ISO system of limits and fits —Part 1: Bases of tolerances, deviations and fits.*

*ISO 286-2:1988, ISO system of limits and fits —Part 2: Tables of standard tolerance grades and limit deviations for holes and shafts.*

*ISO 885:2000, General purpose bolts and screws —Metric series —Radii under the head.*

*ISO 965-3:1998, ISO general purpose metric screw threads —Tolerances —Part 3: Deviations for constructional screw threads.*

*ISO 1101:2000, Geometrical Product Specifications (GPS)—Geometrical tolerancing —Tolerances of form, orientation, location and run-out.*

*ISO 1478:1999, Tapping screws thread.*

*ISO 1479:1983, Hexagon head tapping screws.*

*ISO 2692:1988, Technical drawings —Geometrical tolerancing—Maximum material principle.*

*ISO 4032:1999, Hexagon nuts, style 1—Product grades A and B.*

*ISO 4042:1999, Fasteners —Electroplated coatings.*

*ISO 4757:1983, Cross recesses for screws.*

*ISO 7053:1992, Hexagon washer head tapping screws.*

*ISO 7721:1983, Countersunk head screws —Head configuration and gauging.*

*ISO 8015:1985, Technical drawings —Fundamental tolerancing principle.*

*ISO 10509:1992, Hexagon flange head tapping screws.*

*ISO 10642:1997, Hexagon socket countersunk head screws.*

*ISO 10664:1999, Hexalobular internal driving feature for bolts and screws.*



### 3 Tolerances for metric bolts, screws and studs

#### 3.1 Dimensional tolerances

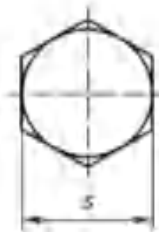
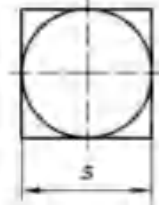
Symbols and designations of dimensions are specified in ISO 225.

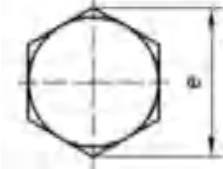
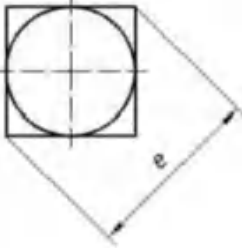
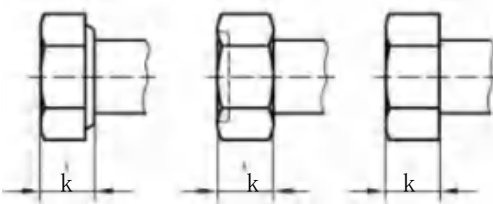
Feature	Tolerance for product grades			Notes
	A	B	C	
<b>3.1.1 Tolerance level</b>  Shank and bearing surface Other features	close  close	close  wide	wide  wide	
<b>3.1.2 External thread</b>	6g	6g	8g (but 6g for property class 8.8 and higher)	For certain products and coatings, other tolerance classes for threads may be specified in the relevant product and coating standards.
<b>3.1.3 Driving features</b>				
<b>3.1.3.1 External</b>	S	S	S	
<b>3.1.3.1.1 Width across flats</b>	Tolerance ≤30 h13 >30 h14	Tolerance ≤18 h14 >18≤60 h15 >60≤180 h16 >180 h17	Tolerance h14 h15 h16 h17	
 <p>Figure 1</p>  <p>Figure 2</p>				

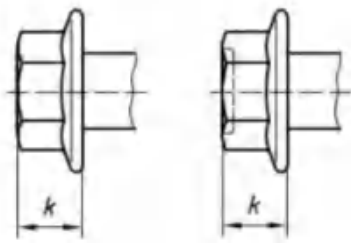
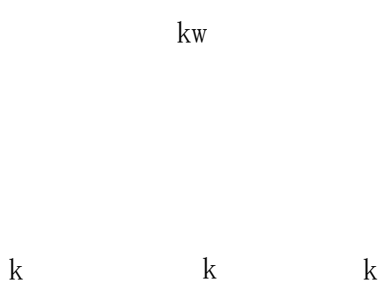
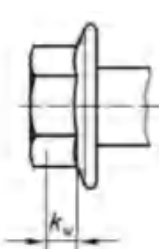
Feature	Tolerance for product grades			Notes						
	A	B	C							
3.1.3.1.2 Width across corners  Figure 3	$e_{min} = 1, 1, 3 \text{ smin}$ $e_{min} = 1, 1, 2 \text{ smin}$ for bolts and screws with flange and other cold forged heads without trimming operation									
 Figure 4		$e_{min} = 1, 3 \text{ smin}$								
3.1.3.1.3 Height of head  Figure 5	js14	js15	<table border="1"> <thead> <tr> <th>k</th> <th>Tolerance</th> </tr> </thead> <tbody> <tr> <td>&lt;10</td> <td>js16</td> </tr> <tr> <td>≥10</td> <td>js17</td> </tr> </tbody> </table>	k	Tolerance	<10	js16	≥10	js17	
k	Tolerance									
<10	js16									
≥10	js17									

Feature	Tolerance for product grades			Notes
	A	B	C	
 <p>Figure 6</p>	For hexagon bolts and screws with flange, k is defined only as a maximum			
<p>3.1.3.1.4 Wrenching height</p> <p>kw</p>  <p>Figure 7</p>	$kw_{min} = 0,7 k_{min}$			kw defines the length over which emin applies but excluding any chamfer, washer face or radius specified in the appropriate product standard  The formulae for kw min only apply to the products illustrated. aThe symbol kw replaces the previously used K.
 <p>Figure 8</p>	$m - 0,7 (k_{mx} - r_{i5}) - \{ +w_{m} - a_{noma} \}$ x is the greater of $c_{min} \times 1,25$ or $C_{min} + 0,4$ 8 is the flange angle Dimensions kwa, k, dw, e and $\delta$ are in accordance with ISO 225.			b For gauging see annex A of the product standards
			 <p>Figure 8 a)</p>	

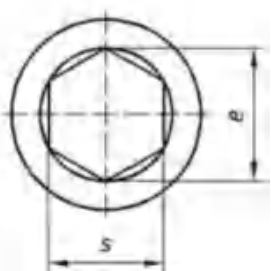
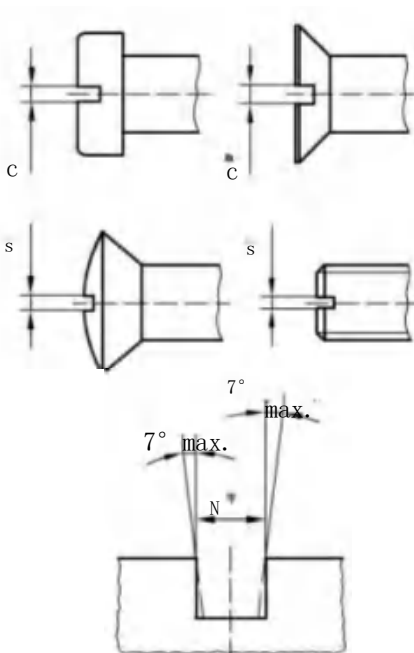

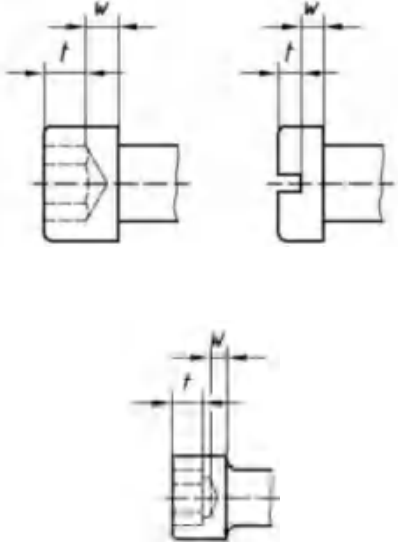
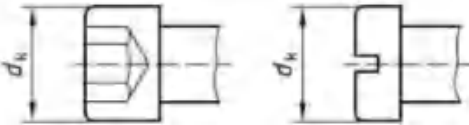
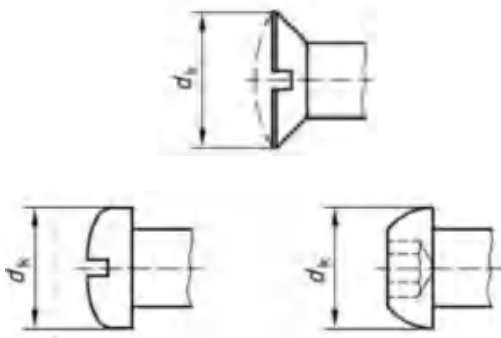
Feature	Tolerance for product grades		B	C	Notes	
	A					
3.1.3.2 Internal 3.1.3.2.1 Hexagon sockets	$e_{min} = 1,14 S_{min}$ $s$	Tolerance				
 <p>Figure 9</p>	0,7	EF8				
	0,9	JS9				
	1,3	K9				
	1,5 2 2,5 3	D11	-	-		
	4	E11				
	5 6 8 10 12 14	E12				
	>14	D12				
	3.1.3.2.2 Slots	$n$	Tolerance			
	 <p>Figure 10</p>	$\leq 1$	+0,20 +0,06			Tolerance field C13 for $n \leq 1$
		$>1 \leq 3$	+0,31 +0,06			C14 for $n > 1$
$>3 \leq 6$		+0,37 +0,07				

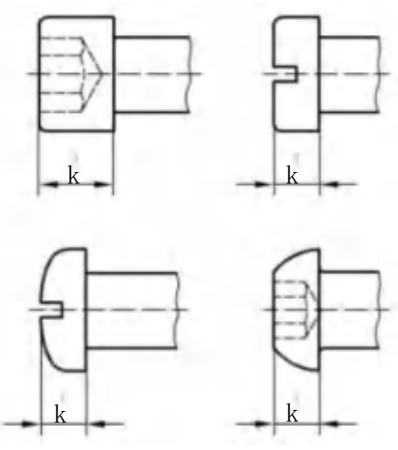
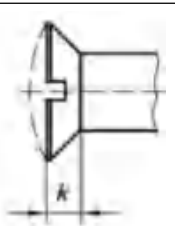
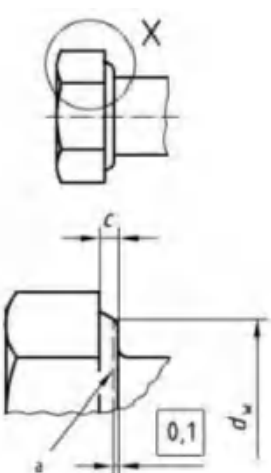
Feature	Tolerance for product grades			Notes
	A	B	C	
<b>3.1.3.2.3 Depth of hexagon sockets and slots</b>  <p style="text-align: center;">Figure 11</p>	The depth of hexagon sockets and slots is specified in product standards only as a minimum. It is restricted by the minimum wall thickness $w$ .	—		For the time being generally applicable tolerances cannot be specified
<b>3.1.3.2.4 Cross recesses</b>	See ISO4757 for all dimensions except penetration depths. For penetration depths see appropriate product standard			
<b>3.1.3.2.5 Hexalobular recesses</b>	See ISO10664 for all dimensions except penetration depths. For penetration depths see appropriate product standard.			
<b>3.1.4 Other features</b> <b>3.1.4.1 Head diameter</b>  <p style="text-align: center;">Figure 12</p>	h13a	—	—	a+IT13 for knurled heads
 <p style="text-align: center;">Figure 13</p>	h14	—	—	Combined control of diameter and height for counter-sunk head screws in accordance with ISO7721 or ISO 10642.

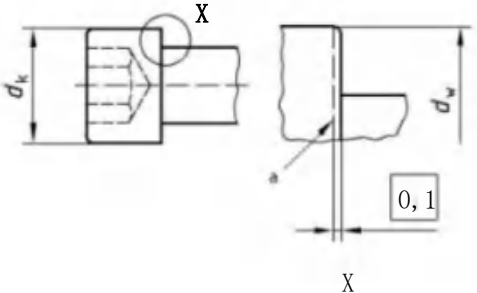
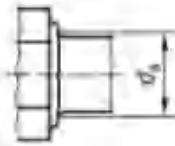
Feature	Tolerance for product grades			Notes
	A	B	C	
<b>3.1.4.2 Head height (except for hexagon heads)</b>  <p style="text-align: center;">Figure 14</p>	$\leq M5: h13$ $> M5: h14$		—	
 <p style="text-align: center;">Figure 15</p>	For countersunk head screws k is defined in product standards only as a maximum.			Combined control of diameter and height for countersunk head screws in accordance with ISO 7721 or ISO 10642.
<b>3.1.4.3 Bearing face diameter and height of washer-faced portion</b>  <p style="text-align: center;">X</p> <p>a Reference datum for dw</p> <p style="text-align: center;">Figure 16</p>	$dw_{min} = S_{min} - IT16$ for width across flats $< 21$ mm $dw_{min} = 0,95 s_{min}$ for width across flats $\geq 21$ mm $dw_{max} = S_{actual}$		C	For product grade Ca washer face is not mandatory
Thread diameter	min.	max.		
$\geq 1.6$ to 2.5	0,10	0,25		
$> 2,5$ to 4	0,15	0,40		
$> 4$ to 6	0,15	0,50		
$> 6$ to 14	0,15	0,60		
$> 14$ to 36	0,20	0,80		
$> 36$	0,30	1,0		

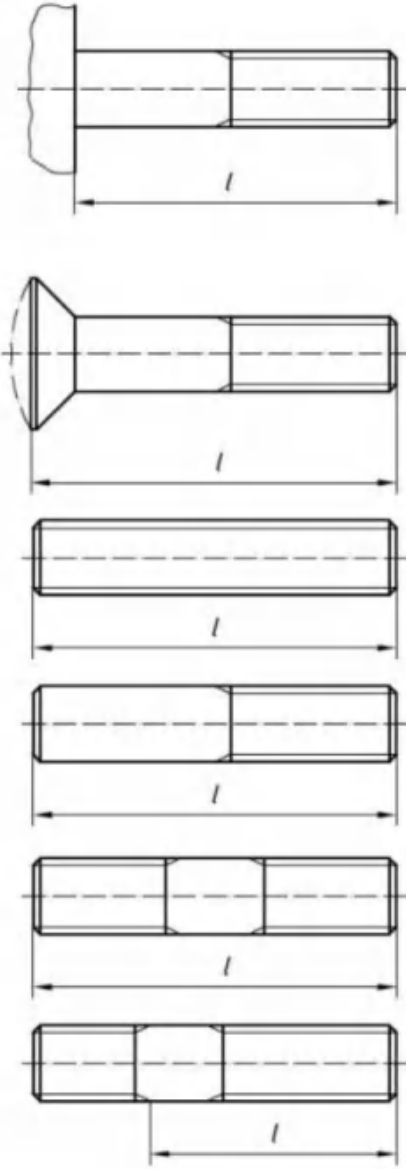
Feature	Tolerance for product grades			Notes																
	A	B	C																	
 <p>0,1</p> <p><b>X</b></p> <p>a Reference datum for dw <b>Figure 17</b></p>	<p>dw is defined in product standards only as a minimum</p>																			
 <p>a Reference datum for dw <b>Figure 18</b></p>	<table border="1"> <thead> <tr> <th>Thread diameter</th> <th>dw min.</th> </tr> </thead> <tbody> <tr> <td>&gt;</td> <td>min.</td> </tr> <tr> <td>2,5</td> <td>dk min-0,14</td> </tr> <tr> <td>5</td> <td>dk min-0,25</td> </tr> <tr> <td>10</td> <td>dk min-0,4</td> </tr> <tr> <td>16</td> <td>dk min-0,5</td> </tr> <tr> <td>24</td> <td>dk min-0,8</td> </tr> <tr> <td>36</td> <td>dk min-1</td> </tr> <tr> <td></td> <td>dk min-1,2</td> </tr> </tbody> </table>	Thread diameter	dw min.	>	min.	2,5	dk min-0,14	5	dk min-0,25	10	dk min-0,4	16	dk min-0,5	24	dk min-0,8	36	dk min-1		dk min-1,2	<p>For product grade A only</p>
Thread diameter	dw min.																			
>	min.																			
2,5	dk min-0,14																			
5	dk min-0,25																			
10	dk min-0,4																			
16	dk min-0,5																			
24	dk min-0,8																			
36	dk min-1																			
	dk min-1,2																			
 <p><b>Figure 19</b></p>	<p>da for undercut products, see the appropriate product standard in ISO885.</p>			<p>da for undercut products, see the appropriate product standard</p>																

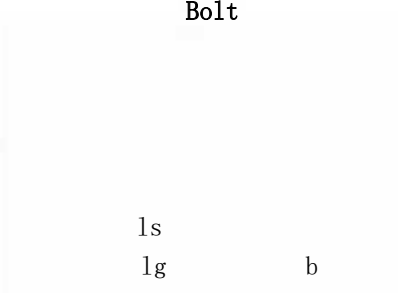
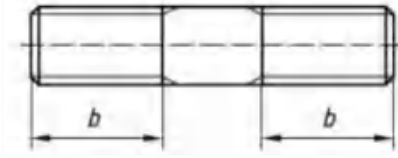
Feature	Tolerance for A	product grades B	C	Notes
<p>3.1.4.4 Length</p>  <p>Figure 20</p>	js15	js17	$l \leq 150$ : js17 $l > 150$ : $\pm IT17$	

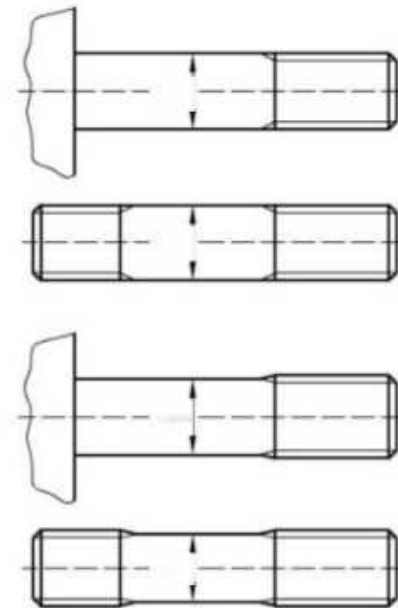
Feature	Tolerance for product grades			Notes
	A	B	C	
<p>3.1.4.5 Thread length</p> <p><b>Bolt</b></p>  <p><b>Tie rod</b></p>  <p><b>Stud</b></p>  <p>Figure 21</p>	$b+2P$ 0	$b+2P$ 0	$b+2P$ 0	<p>P is the pitch of thread.</p> <p>lg is the minimum length of the unthreaded (plain) shank.</p> <p>lg is the maximum length of the unthreaded shank (thread run-out included) and is therefore the minimum clamping length</p> <p>Tolerance +2 P related to dimension b applies only where ls and I are not specified in the product standard.</p> <p>bm refers to metal end of studs only.</p>
<p>3.1.4.6 Shank diameter</p>  <p>Figure 22</p>	$h13$	$h14$	$\pm IT 15$	<p>The tolerance is not applicable in the areas of the underhead fillet and thread run-out.</p>
Reduced shank diameter $\approx$ pitch diameter				

### 3.2 Geometrical tolerances

In accordance with ISO 1101 and ISO 2692 the tolerances specified in Figures 23 to 57 do not necessarily imply the use of any particular method of production, measurement or gauging.

When the pitch diameter axis is specified as the datum and the coaxiality deviation of the major diameter axis relative to the pitch diameter axis is negligible, e.g. normally with rolled threads, the major diameter axis may be taken as the datum.

According to ISO 1101 when the datum is the thread axis the letters MD indicate that the datum reference is the major diameter axis.

The maximum material principle in accordance with ISO 2692 is used.

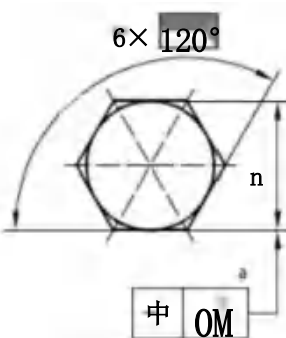
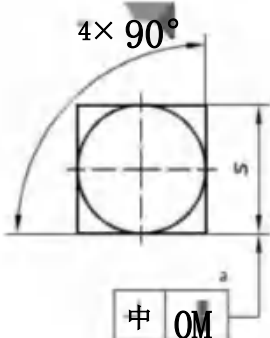
Feature	Tolerance for product grades			Notes
	A	B	C	
<p>3.2.1 Driving feature</p> <p>3.2.1.1 Tolerances of form</p> <p>3.2.1.1.1 External</p>  <p>a 3x simultaneously Figure 23</p>  <p>a 2x simultaneously Figure 24</p>				

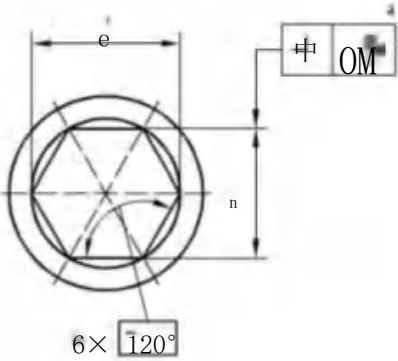
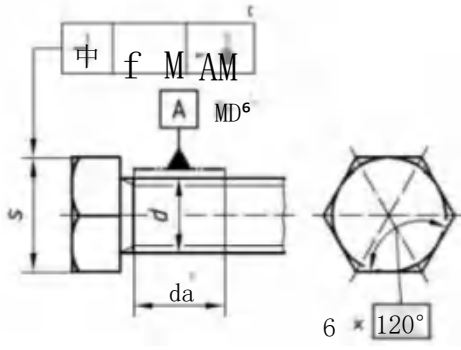
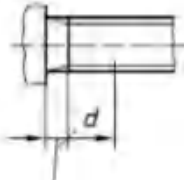
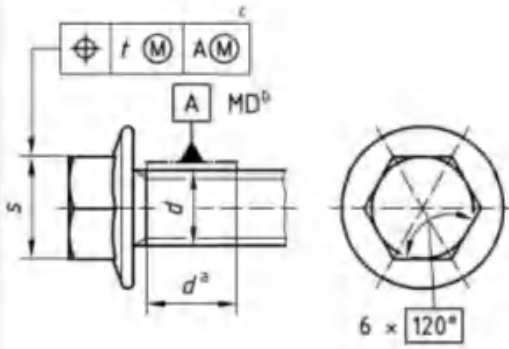
Feature	Tolerance A	Tolerance B	Tolerance C	Tolerance t based on dimensions	Notes
<p>3.2.1.1.2 Internal</p>  <p>a 3×simultaneously.</p> <p>Figure 25</p>					
<p>3.2.1.2 Tolerances of position</p>  <p>a The datum A shall be as close to the head as possible but within 0,5d distance of the head and shall be either wholly plain or wholly threaded but shall not include the thread run-out or underhead fillet.</p> <p>b MD means that tolerance applies in relation to the axis of the cylinder derived from the major thread diameter.</p> <p>c 3×simultaneously.</p> <p>Figure 26</p>	2 IT13	2 IT14	2 IT15	S	<p>d</p> <p>0,5d max.</p>  <p>0,5d max</p>
 <p>a,b,c See Figure 26.</p> <p>Figure 27</p>	2 IT13	2 IT14	—	s	

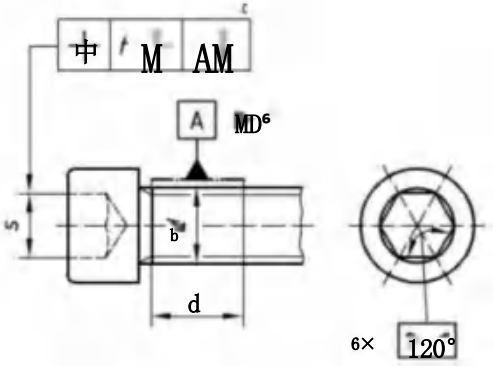
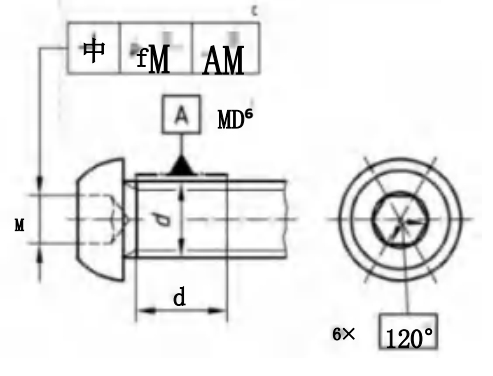
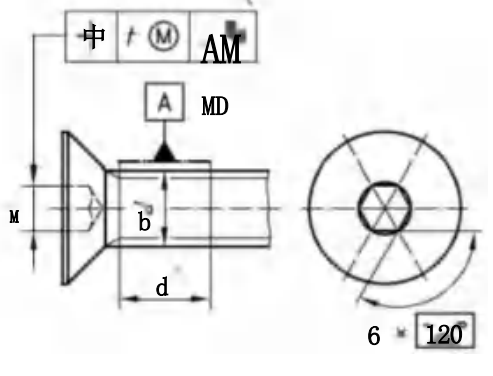
Feature	Tolerance A	Tolerance B	Tolerance C	Tolerance t based on dimensions	Notes
 <p>a, b, c See Figure 26 Figure 28</p>	2 IT13		-	d	
 <p>a, b, c See Figure 26 Figure 29</p>	2 IT13			d	
 <p>a, b, c See Figure 26 Figure 30</p>	2 IT13			d	

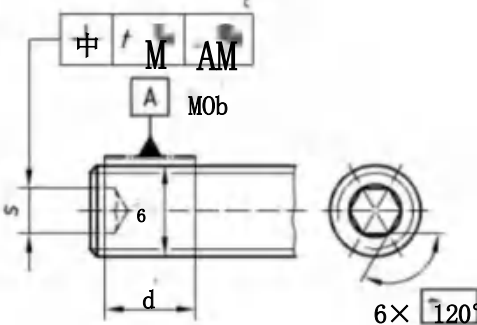
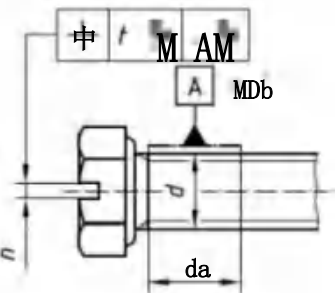
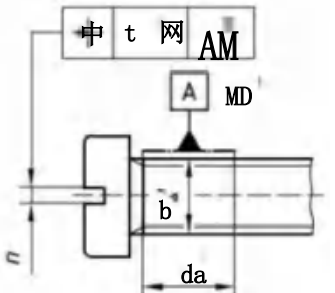
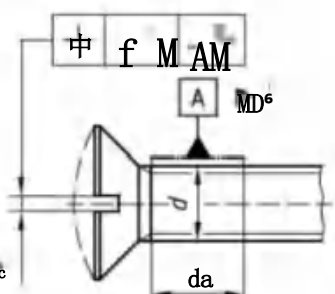
Feature	Tolerance A	Tolerance B	Tolerance C	Tolerance based on dimensions	Notes
 <p>b, c See Figure 26 Figure 31</p>	2 IT12			d	
 <p>a, b See Figure 26 Figure 32</p>	2 IT12	2 IT13	2 IT14	d	
 <p>a, b See Figure 26 Figure 33</p>	2 IT12	2 IT13	2 IT14	d	
 <p>a, b See Figure 26 Figure 34</p>	2 IT12	2 IT13	2 IT14	d	

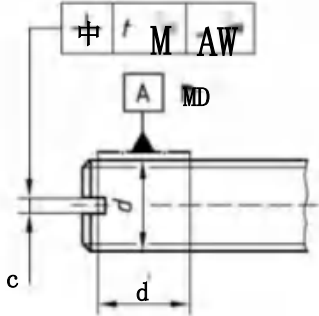
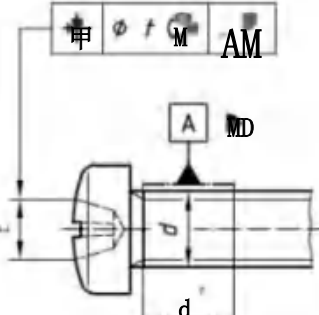
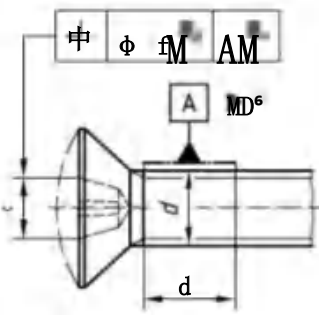
Feature	Tolerance A	Tolerance B	Tolerance C	Tolerance t based on dimensions	Notes
 <p>b See Figure 26 Figure 35</p>	2 IT12	—		d	
 <p>a, b See Figure 26 c For referee purposes coaxiality of cross section shall be assessed by means of a penetration gauge point in accordance with ISO 4757. Figure 36</p>	2 IT13			d	
 <p>a, b See Figure 26 c See Figure 36. Figure 37</p>	2 IT13			d	

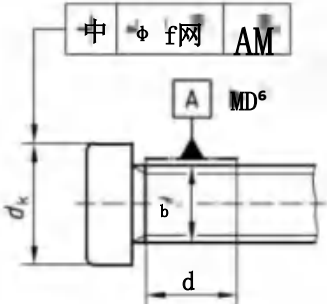
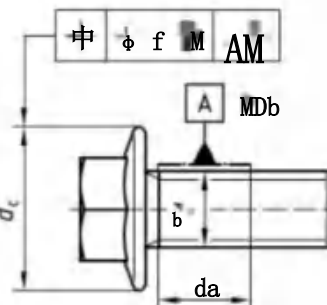
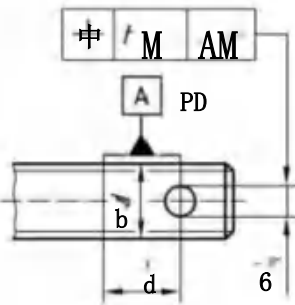
Feature	Tolerance A	Tolerance B	Tolerance C	Tolerance based on dimensions	Notes
<p>3.2.2 Other features</p> <p>3.2.2.1 Tolerances of position and run-out</p>  <p>a, b See Figure 26</p> <p>Figure 38</p>  <p>a, b See Figure 26</p> <p>Figure 39</p>  <p>C PD means that the tolerance applies in relation to the axis derived from the pitch diameter</p> <p>Figure 40</p>	<p>2 IT13</p> <p>2 IT13</p> <p>2 IT13</p>	<p>2 IT14</p> <p>2 IT14</p> <p>2 IT14</p>	<p>2 IT15</p> <p>2 IT14</p> <p>2 IT15</p>	<p>dk</p> <p>do</p> <p>d</p>	

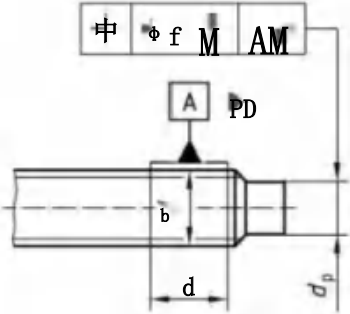
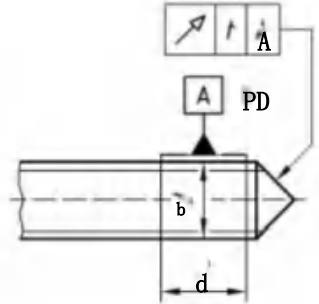
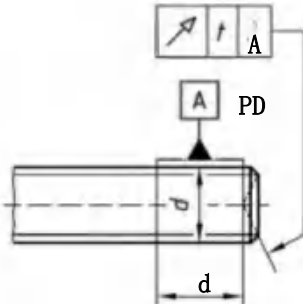
Feature	Tolerance A	Tolerance B	Tolerance C	Tolerance based on dimensions	Notes
 <p>C See Figure 40. Figure 41</p>	IT13d 2 IT13e			d	d For set screws. e For all other products
 <p>C See Figure 40. Figure 42</p>	IT13			d	
 <p>C See Figure 40. Figure 43</p>	IT13			d	

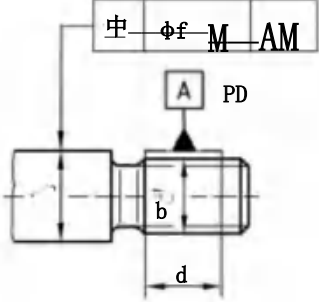
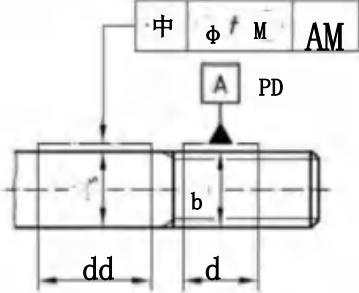
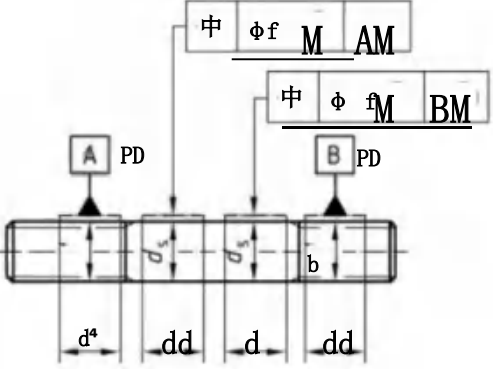
Feature	Tolerance for product grades			Tolerance based on dimensions	Notes
	A	B	C		
 <p>C See Figure 40 Figure 44</p>	2 IT13	2 IT14	2 IT15	d	
 <p>C See Figure 40 d The gauge datum feature A shall be as close to the respective part of the shank as possible but shall avoid the thread run-out. Figure 45</p>	IT13	IT14	IT15	d	
 <p>c See Figure 40 d gauge datum features A and B shall be as close to the respective part of the shank as possible but shall avoid the thread Figure 46</p>	IT13	IT14		d	

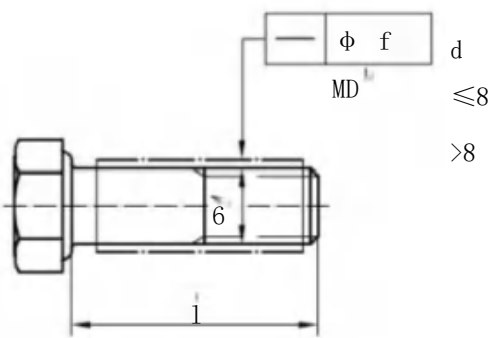
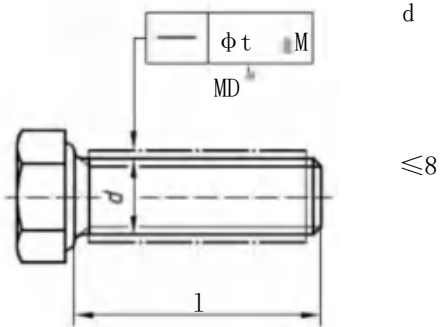
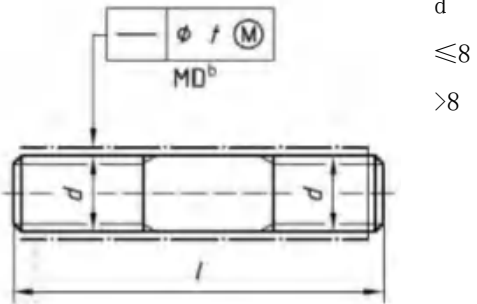
Feature	Tolerance for product grades			Tolerance based on dimensions	Notes
	A	B	C		
<p>3.2.2.2 Tolerances of straightness</p>  <p>b See Figure 26 Figure 47</p>	$t=0,00$ $t=0,002$	$21+0,05$ $51+0,05$	$d \le 8: 1=2 (0,0021+0,05)$ $d < 8: =2 (0,002 51+0,05)$		
 <p>b See Figure 26 Figure 48</p>	$t=0,0021+0,05$ $t=0,00251+0,05$		$d \le 8: 1=2 (0,0021+0,05)$ $d < 8: 1=2 (0,002 5/+0,05)$		
 <p>b See Figure 26. Figure 49</p>	$t=0,0021+0,05$ $t=0,00251+0,05$				

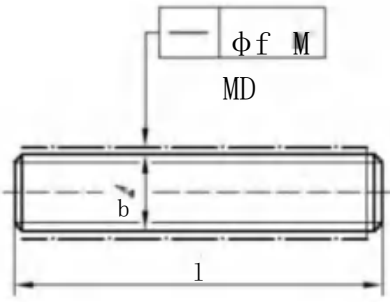
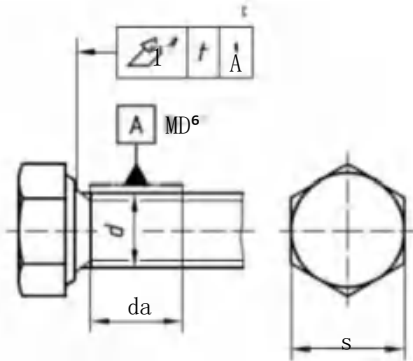
Feature	Tolerance for product grades			Tolerance t based on dimension d	Notes
	A	B	C		
 <p>b See Figure 26. <b>Figure 50</b></p>			$d \leq 8: 1=2(0,0021+0,05)$ $d > 8: t=2(0,0025+0,05)$		
<p><b>3.2.2.3 Tolerance of total run-out</b></p>  <p>a, b See Figure 26 c Up to 0,8s diameter only. <b>Figure 51</b></p>	0,04			1,6	For product grades A and B tolerance t is calculated as follows: $\leq M 39:$ $t=1,2 d \tan 1^\circ$ $> M 39:$ $t=1.2 d \tan 0.5$ For product grade C tolerance t is twice as much.
	0,08		0,3	2	
				2,5	
				3	
				3,5	
				4	
	0,15		0,3	5	
				6	
				7	
	0,17	0,34		8	
	0,21	0,42		10	
	0,25	0,50		12	
	0,29	0,58		14	
	0,34	0,68		16	
	0,38	0,76		18	
	0,42	0,84		20	
	0,46	0,92		22	
	0,50	1,00		24	
	0,57	1,14		27	
	0,63	1,26		30	
	0,69	1,38		33	
	0,76	1,52		36	
	0,82	1,64		39	
	0,44	0,88		42	
	0,47	0,94		45	
	0,50	1		48	
	0,55	1,1		52	

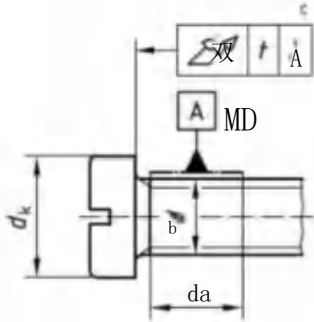
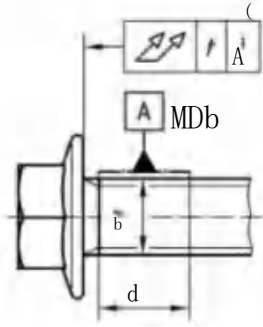
Feature	Tolerance t for product grades		Tolerance t based on dimension d	Notes	
	A	B			C
 <p>a, b See Figure 26            0 Up to 0,8 dk diameter only.</p> <p><b>Figure 53</b></p>  <p>a, b See Figure 26            c Line of highest points on any radial line</p> <p><b>Figure 54</b></p>	0,04		1,6	See Figures 51 and 52  In case of flange bolts, tolerances apply to type F and type U.	
			—		2
	0,08		0,3		2,5
					3
					3,5
					4
					5
	0,15				6
					7
	0,17		0,34		8
	0,21		0,42		10
	0,25		0,50		12
	0,29		0,58		14
	0,34		0,68		16
	0,38		0,76		18
	0,42		0,84		20
	0,46		0,92		22
	0,50		1,00		24
	0,57		1,14		27
0,63		1,26	30		
0,69		1,38	33		
0,76		1,52	36		
0,82		1,64	39		
0,44		0,88	42		
0,47		0,94	45		
0,50		1	48		
0,55		1,1	52		

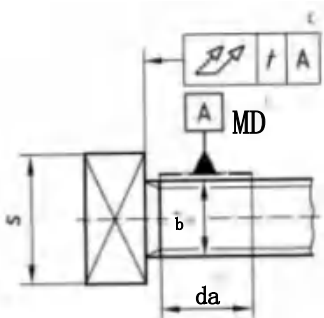
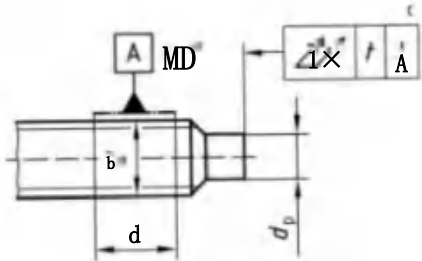
Feature	Tolerance t for product grades			Tolerance t based on dimensions	Notes
	A	B	C		
 <p>a, b See Figure 26 c See Figure 51.</p> <p>Figure 55</p>	For t see Figures 51 to 54			Basis for t see Figures 51 to 54	For dog points only, not for pilot points
 <p>a, b See Figure 26. C Up to 00,8d<sub>o</sub> only</p> <p>Figure 56</p>					

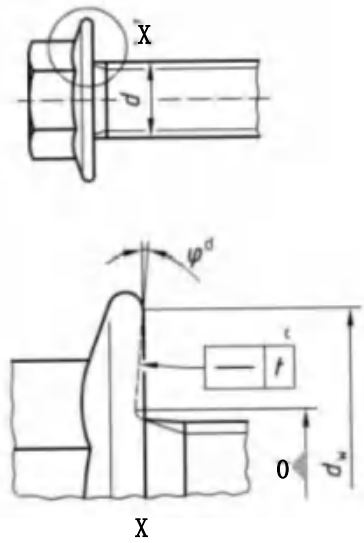
Feature	Tolerance t for product grades			Tolerance t based on dimensions	Notes
	A	B	C		
<p>3.2.2.4 Permissible deviation from the form of bearing face</p>  <p>C radial lines between <math>d_{max}</math> and <math>d_{w \min}</math>  d According to product standard.</p> <p>Figure 57</p>			0,005 d	d	



## 4 Tolerances for metric nuts

### 4.1 Dimensional tolerances

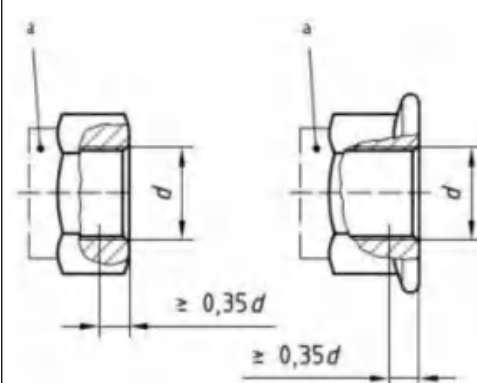
NOTE Symbols and designations of dimensions are specified in ISO 225.

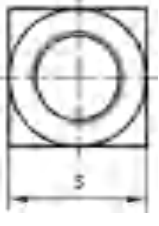
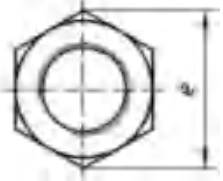
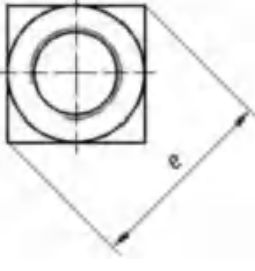
Feature	Tolerance for product grades			Notes
	A	B	C	
<b>4.1.1 Tolerance level</b> Bearing surface Other features	close close	close wide	wide wide	
<b>4.1.2 Internal thread</b> $\geq 0,5\text{mm}$ $\geq 0,5\text{mm}$  $m$ $E$ $d$ $0,35\text{mm}$  a Profile varies for different types of prevailing torque type nuts. <b>Figure 58</b>	6H	6H	7H	For certain products and coatings, other tolerance classes may be specified in the relevant product and coating standards.  For all nuts of heights $m \geq 0,8d$ the minor diameter shall be within the specified tolerances for a minimum of $0,5\text{mm}$ (only for sizes $\geq M3$ ).  For all nuts of heights $0,5d \leq m < 0,8d$ the minor diameter shall be within the specified tolerances for a minimum of $0,35\text{mm}$  For prevailing torque type nuts the minor diameter may exceed the specified tolerance for a maximum height of $0,35d$ from the non-restricted end which does not contain the prevailing torque feature.

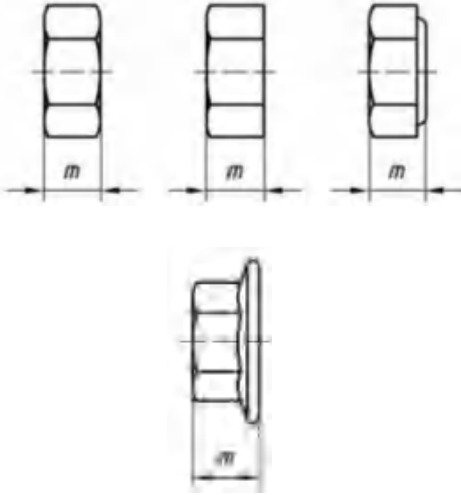
Feature	Tolerance for product grades				Notes
	A		B	C	
4.1.3 Driving features 4.1.3.1 Width across flats  Figure 59	S	Tolerance	S	Tolerance	
	$\leq 30$ $> 30$	h13 h14	$\leq 18$ $> 18 \leq 60$ $> 60 \leq 180$ $> 180$	h14 h15 h16 h17	
 Figure 60	See figure 59		See figure 59		
4.1.3.2 Width across corners  Figure 61	$e_{min} = 1, 13 \text{ s}_{min}$				
 Figure 62	$C_{min} = 1, 3 \text{ s}_{min}$				

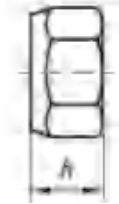
Feature	Tolerance for product grades		Notes
	A	B	
4.1.4 Other features 4.1.4.1 Height of nuts  <p style="text-align: center;">Figure 63</p>	$d \leq 12 \text{ mm} : h14$ $12 \text{ mm} < d \leq 18 \text{ mm} : h15$ $d > 18 \text{ mm} : h16$		h17  For slotted nuts and castle nuts see 4.1.5.1
Prevailing torque type nuts (with non-metallic insert)  Prevailing torque type all metal hexagon nuts  <p style="text-align: center;">Figure 64</p>	Tolerance of h, see product standards		

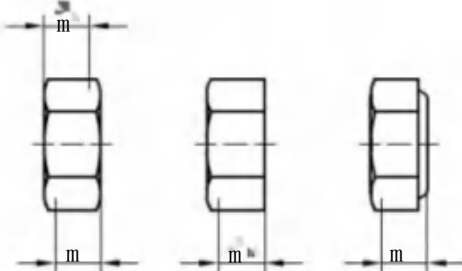
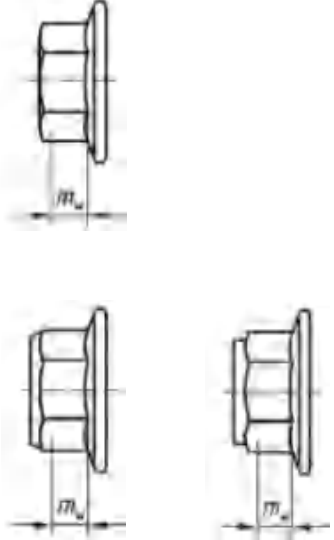
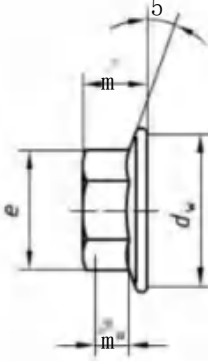
Feature	Tolerance for product grades			Notes
	A	B	C	
<p>4.1.4.2 Wrenching height</p>  <p>Figure 65</p>	$m_{w \min} = 0,8 m_{\min}$			<p><math>m_w</math> defines the length over which <math>e_{\min}</math> applies but excluding any chamfer or washer face specified in the appropriate product standard</p> <p>The symbol <math>m_w</math> replaces the previously used <math>m'</math>.</p>
 <p>Figure 66</p>	$m_{w \min}^b = 0,8 \left[ m_{\min} - \left( x + \frac{d_{w \min} - r_{\min}}{2} \tan \delta_{\max} \right) \right]$ <p><math>x</math> is the greater of <math>C_{\min} \times 1,25</math> or <math>C_{\min} + 0,4</math></p> <p><math>\delta</math> is the flange angle</p> <p>Dimensions <math>m_w, m, d_w, e</math> and <math>\delta</math> are in accordance with ISO225</p> 			<p>a The formulae for <math>m_{w \min}</math> only apply to the products illustrated.</p> <p>b For gauging see annex A of the product standards.</p>

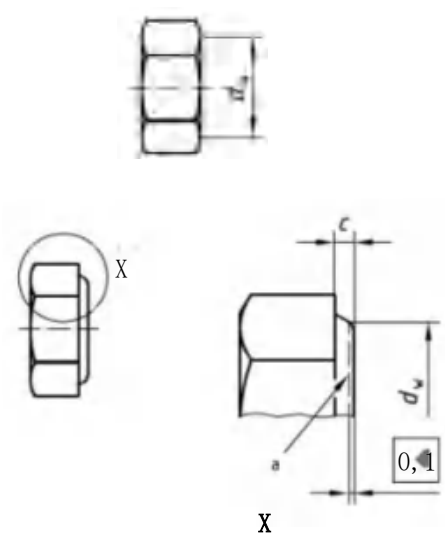
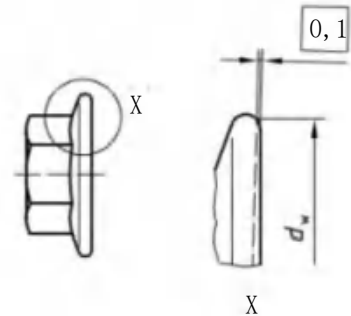
Feature	Tolerance for product grades			Notes
	A	B	C	
<b>4.1.4.3 Bearing face diameter and height of washer-faced portion</b>    a Reference datum for dw <b>Figure 67</b>	dw min=5min-IT16 for width across flats<21 mm dw min=0,95 smin for width across flats≥21 mm dw max=Sactual			Requirements apply to both sides of symmetrical parts
	<b>Thread diameter</b>	C		
		min.	max.	
≥1,6 to 2,5 >2,5 to 4 >4 to 6 >6 to 14 >14 to 36 >36	0,10 0,15 0,15 0,15 0,2 0,3	0,25 0,40 0,50 0,60 0,8 1,0		
  <b>Figure 68</b>	dw min for hexagon nuts with flange in accordance with product standards			

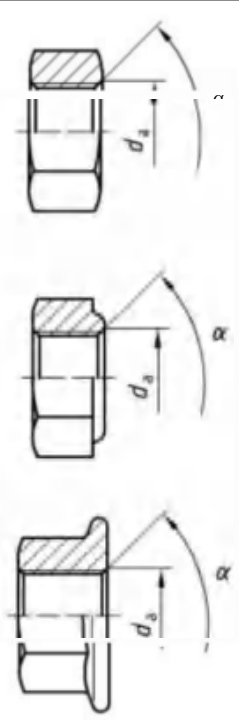
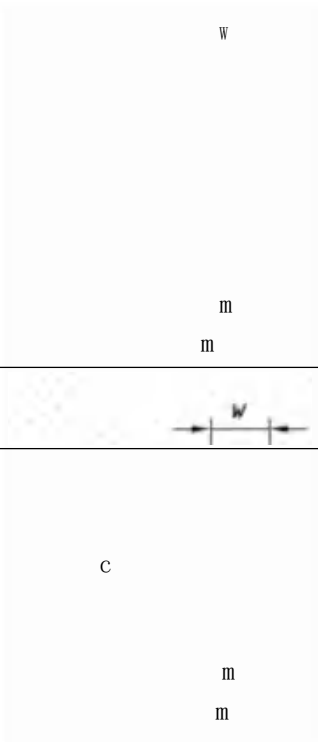
Feature	Tolerance for product		grades	Notes
	A	B	C	
 <p><math>\alpha = 90^\circ</math> to <math>120^\circ</math></p> <p>Figure 69</p>	$d \leq 5$ mm: $d_{a \max} = 1,15d$ $5$ mm $< d \leq 8$ mm: $d_{a \max} = d + 0,75$ $d > 8$ mm: $d_{a \max} = 1,08d$ for all sizes: $d_{a \min} = d$			Requirements apply to both sides of symmetric parts
<p>4.1.5 Special products</p> <p>4.1.5.1 Castle nuts, slotted nuts</p>  <p>Figure 70</p>				
	de	h14	h15	h16
	m	h14	h15	h17
	n	H14	H14	H15
	w	h14	h15	h17
	mw	see mw-values for hexagon nuts style 1 (see ISO 4032)		

## 4.2 Geometrical tolerances

In accordance with ISO 1101 and ISO 2692 the tolerances specified in Figures 71 to 83 do not necessarily imply the use of any particular method of production, measurement or gauging.

Where the nut thread is used as the datum the pitch diameter shall be the reference diameter.

The maximum material principle in accordance with ISO 2692 is used.

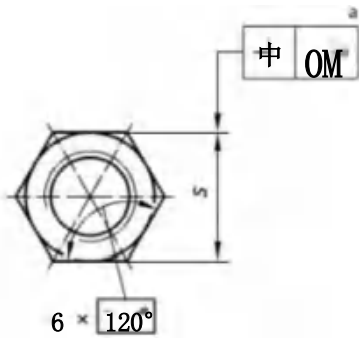
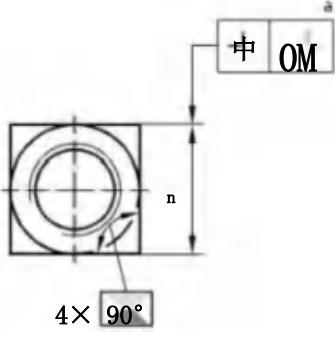
Feature	Tolerance for product grades			Notes
	A	B	C	
<p>4.2.1 Driving features</p> <p>4.2.1.1 Tolerances of form</p>  <p>a 3×simultaneously.</p> <p>Figure 71</p>  <p>a 2×simultaneously.</p> <p>Figure 72</p>				

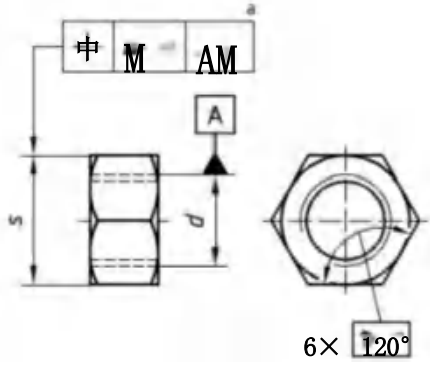
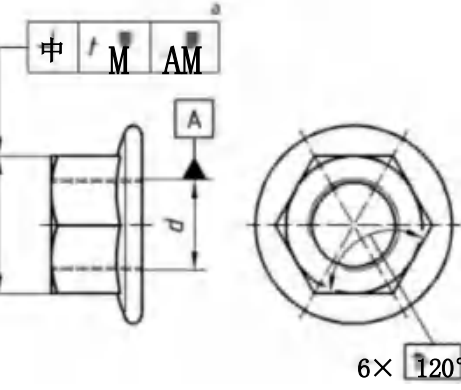
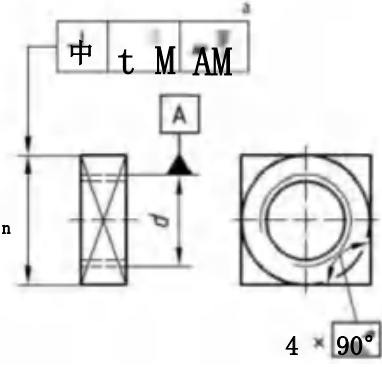
Feature	Tolerance A	Tolerance B	Tolerance C	Tolerance based on dimensions	Notes
<p>4.2.1.2 Tolerances of position</p>  <p>a 3×simultaneously. Figure 73</p>	2 IT13	2 IT14	2 IT15	S	
 <p>a 3×simultaneously Figure 74</p>	2 IT13	2 IT14			
 <p>a 2xsimultaneously Figure 75</p>	2 IT13	2 IT14	2 IT15	S	

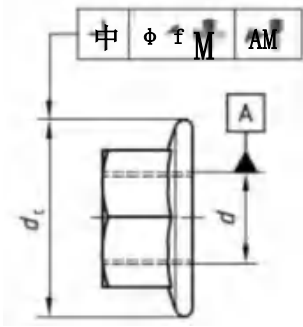
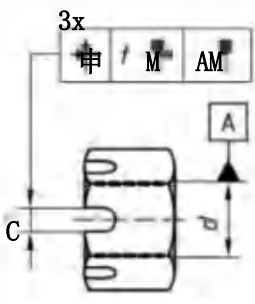
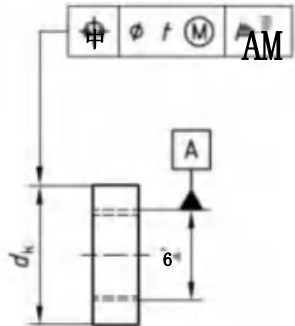
Feature	Tolerance for product grades			Tolerance i based on dimensions	Notes
	A	B	C		
4.2.2 Other features 4.2.2.1 Tolerances of position   <p>Figure 76</p>	2 IT14	2 IT15		dc	
 <p>Figure 77</p>	2 IT13	2 IT14	2 IT15	d	
 <p>Figure 78</p>	2 IT13	2 IT14	—	dk	

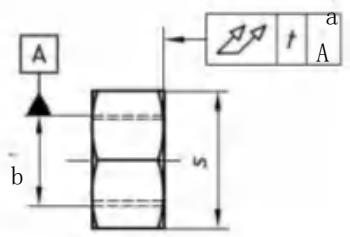
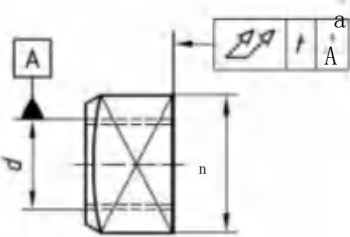
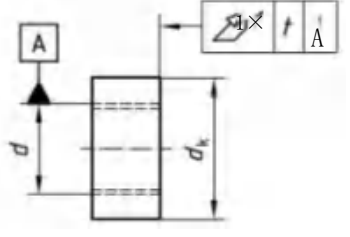

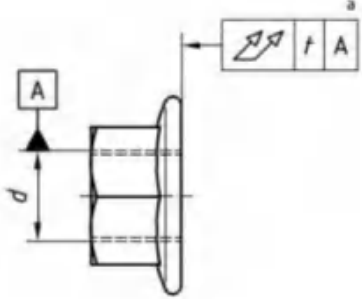
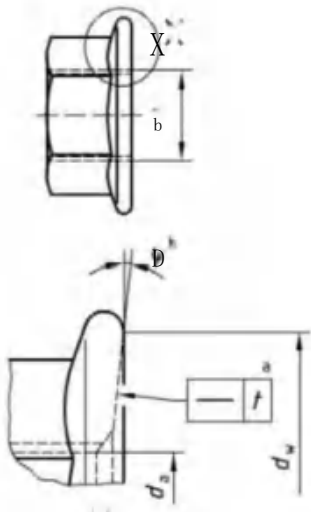
Feature	Tolerance t for product grades			Tolerance t based on dimension d	Notes
	A	B	C		
<p>4.2.2.2 Tolerance of total run-out</p>  <p>a Up to 0,8s diameter only.</p> <p><b>Figure 79</b></p>  <p>a Up to 0,8s only.</p> <p><b>Figure 80</b></p>  <p>a Up to 0,8dk only.</p> <p><b>Figure 81</b></p>	0,04			1,6	For symmetrical parts the perpendicularity requirement shall apply for both faces.
	0,08			2	
				2,5	
				3	
				3,5	
				4	
		0,15	0,3	5	
				6	
				7	
		0,17	0,34	8	
		0,21	0,42	10	
		0,25	0,50	12	
		0,29	0,58	14	
		0,34	0,68	16	
		0,38	0,76	18	
		0,42	0,84	20	
		0,46	0,92	22	
		0,50	1	24	
		0,57	1,14	27	
		0,63	1,26	30	
	0,69	1,38	33		
	0,76	1,52	36		
	0,82	1,64	39		
	0,44	0,88	42		
	0,47	0,94	45		
	0,50	1	48		
	0,55	1,1	52		

Feature	Tolerance t for product grades			Notes
	A	B	C	
 <p>a Line of highest points on any radial line</p> <p><b>Figure 82</b></p>	For t see values for Figures 79, 80 and 81.			
<p><b>4.2.2.3 Permissible deviation from the shape of bearing face</b></p>  <p>a Radial lines between <math>d_{max}</math> and <math>d_{min}</math> • b According to product standard</p> <p><b>Figure 83</b></p>	0,005d			

## 5 Tolerances for tapping screws

### 5.1 Dimensional tolerances—Product grade A

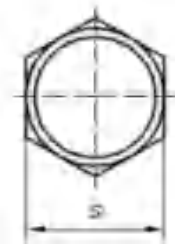
Symbols and designations of dimensions are specified in ISO 225.

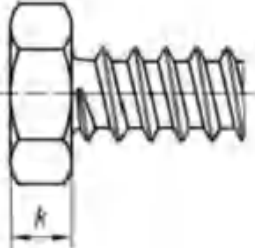
Feature	Tolerance	Notes
5.1.1 Thread	see ISO1478	
5.1.2 Driving features 5.1.2.1 External 5.1.2.1.1 Width across flats  Figure 84	h13	
5.1.2.1.2 Width across corners  Figure 85	$e_{min} = 1,12 S_{min}$	
5.1.2.1.3 Height of head  Figure 86	For tolerances see ISO 1479	For tapping screws with hexagon flange head and hexagon washer head see ISO 7053 and ISO 10509 respectively.

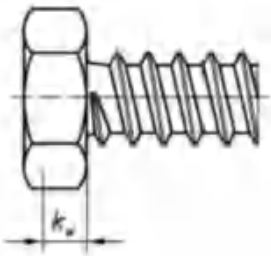
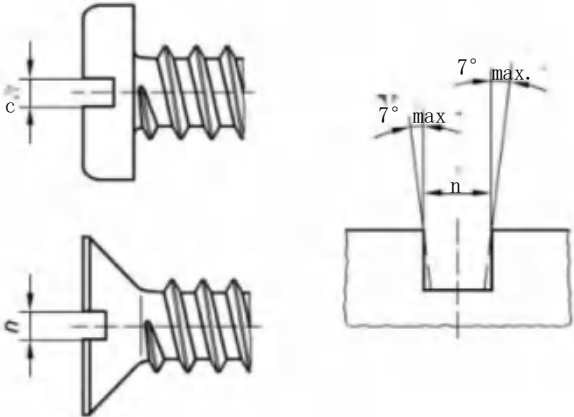
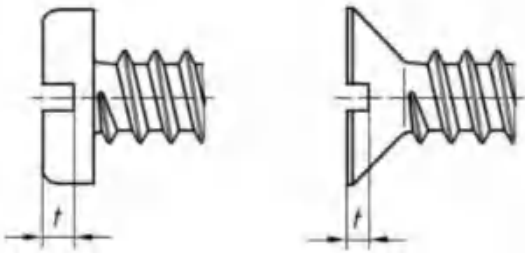
Feature	Tolerance	Notes												
<p>5.1.2.1.4 Wrenching height</p>  <p>Figure 87</p>	<p><math>k_w \text{ min.} = 0,7 k_{\text{min}}</math></p>	<p>For tapping screws with hexagon flange head and hexagon washer head see ISO 7053 and ISO 10509 respectively.</p> <p>The symbol <math>k_w</math> replaces the previously used <math>K</math>.</p>												
<p>5.1.2.2 Internal</p> <p>5.1.2.2.1 Width of slots</p>  <p>Figure 88</p>	<table border="1"> <tr> <td>17</td> <td>Tolerance a</td> <td>a Tolerance field</td> </tr> <tr> <td><math>\leq 1</math></td> <td>+0,20 +0,06</td> <td>C13 for <math>n \leq 1</math></td> </tr> <tr> <td><math>&gt; 1 \leq 3</math></td> <td>+0,31 +0,06</td> <td>C14 for <math>n &gt; 1</math></td> </tr> <tr> <td><math>&gt; 3 \leq 6</math></td> <td>+0,37 +0,07</td> <td></td> </tr> </table>	17	Tolerance a	a Tolerance field	$\leq 1$	+0,20 +0,06	C13 for $n \leq 1$	$> 1 \leq 3$	+0,31 +0,06	C14 for $n > 1$	$> 3 \leq 6$	+0,37 +0,07		
17	Tolerance a	a Tolerance field												
$\leq 1$	+0,20 +0,06	C13 for $n \leq 1$												
$> 1 \leq 3$	+0,31 +0,06	C14 for $n > 1$												
$> 3 \leq 6$	+0,37 +0,07													
<p>5.1.2.2.2 Depth of slots</p>  <p>Figure 89</p>	<p>The depth of slots is specified in product standards.</p>													

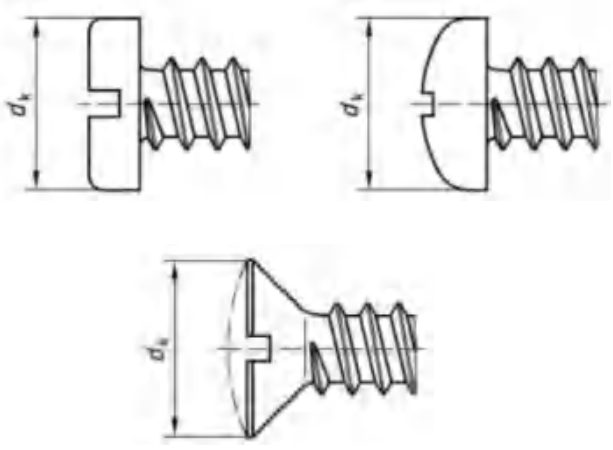
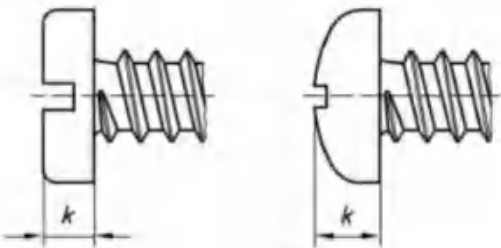
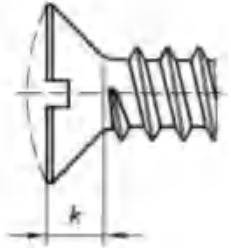
Feature	Tolerance	Notes
5.1.2.2.3 Cross recesses	See ISO 4757 for all dimensions except penetration depths. For penetration depths see appropriate product standard	
5.1.2.2.4 Hexalobular recess	See ISO 10664 for all dimensions except penetration depths. For penetration depths see appropriate product standard.	
<p>5.1.3 Other features</p> <p>5.1.3.1 Head diameters</p>  <p>Figure 90</p>	h14	Combined control of diameter and height for countersunk head screws as specified in ISO 7721.
<p>5.1.3.2 Head height</p>  <p>Figure 91</p>	h14	
 <p>Figure 92</p>	For countersunk head screws k is defined in product standards only as a maximum.	Combined control of diameter and height for countersunk head screws as specified in ISO 7721.

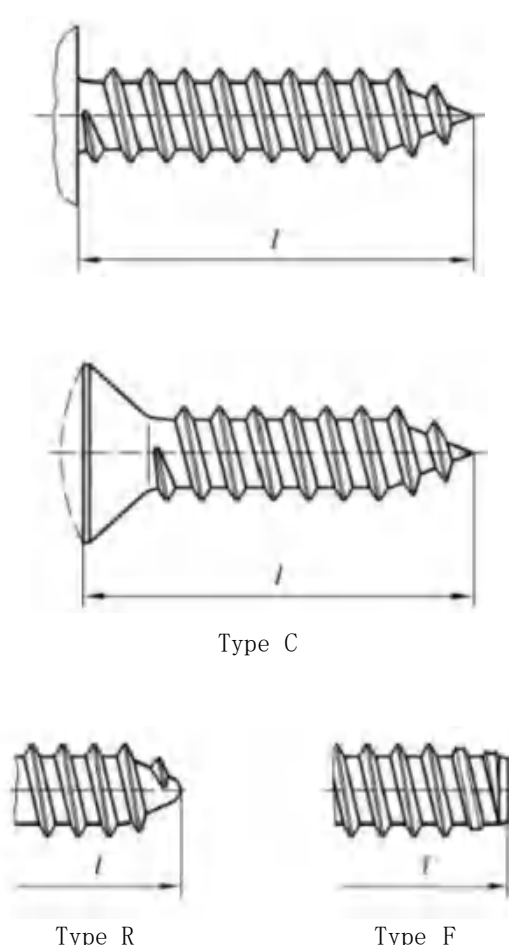
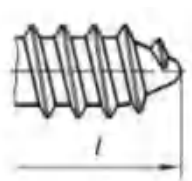
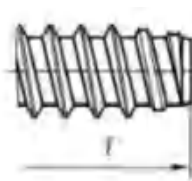
Feature	Tolerance		Notes																		
<p>5.1.3.3 Length</p>  <p style="text-align: center;">Type C</p> <div style="display: flex; justify-content: space-around;"> <div style="text-align: center;">               Type R         </div> <div style="text-align: center;">               Type F         </div> </div> <p style="text-align: center;"><b>Figure 93</b></p>		<table border="1" style="width: 100%; border-collapse: collapse;"> <tr> <td style="text-align: center;"><b>Types</b></td> <td style="text-align: center;"><b>C and R</b></td> </tr> <tr> <td style="text-align: center;">1</td> <td style="text-align: center;">Tolerance</td> </tr> <tr> <td style="text-align: center;"><math>\leq 25</math></td> <td style="text-align: center;"><math>\pm 0,8</math></td> </tr> <tr> <td style="text-align: center;"><math>&gt; 25</math></td> <td style="text-align: center;"><math>\pm 1,3</math></td> </tr> <tr> <td style="text-align: center;"><b>Type F</b></td> <td style="text-align: center;"><b>Tolerance</b></td> </tr> <tr> <td style="text-align: center;">1</td> <td style="text-align: center;">Tolerance</td> </tr> <tr> <td style="text-align: center;"><math>\leq 19</math></td> <td style="text-align: center;">0 -0,8</td> </tr> <tr> <td style="text-align: center;"><math>&gt; 19 \leq 38</math></td> <td style="text-align: center;">0 -1,3</td> </tr> <tr> <td style="text-align: center;"><math>&gt; 38</math></td> <td style="text-align: center;">-1,5</td> </tr> </table>	<b>Types</b>	<b>C and R</b>	1	Tolerance	$\leq 25$	$\pm 0,8$	$> 25$	$\pm 1,3$	<b>Type F</b>	<b>Tolerance</b>	1	Tolerance	$\leq 19$	0 -0,8	$> 19 \leq 38$	0 -1,3	$> 38$	-1,5	
	<b>Types</b>	<b>C and R</b>																			
	1	Tolerance																			
	$\leq 25$	$\pm 0,8$																			
	$> 25$	$\pm 1,3$																			
	<b>Type F</b>	<b>Tolerance</b>																			
	1	Tolerance																			
	$\leq 19$	0 -0,8																			
$> 19 \leq 38$	0 -1,3																				
$> 38$	-1,5																				

## 5.2 Geometrical tolerances—Product grade A

In accordance with ISO 1101 and ISO 2692 the tolerances of form and position indicated in Figures 94 to 104 do not necessarily imply the use of any particular method of production, measurement or gauging.

Where a tapping screw thread is indicated either as the datum or as the toleranced feature the axis shall be determined from the major diameter of the thread.

The maximum material principle in accordance with ISO 2692 is used.

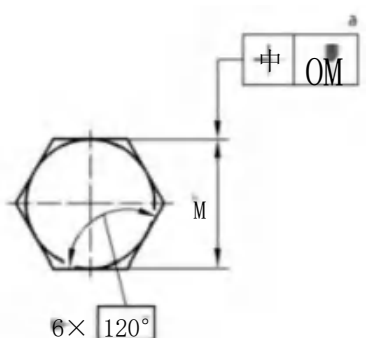
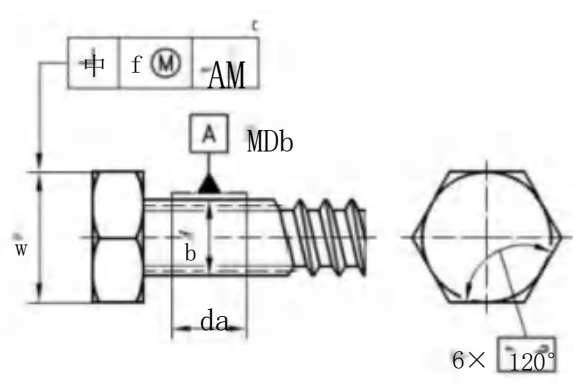
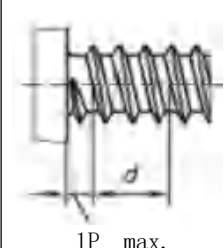
Feature	Tolerance t	Tolerance t based on dimension	Notes
<p>5.2.1 Driving features</p> <p>5.2.1.1 Tolerance of form</p>  <p>a 3×simultaneously.</p> <p><b>Figure 94</b></p>			
<p>5.2.1.2 Tolerances of position</p>  <p>a The datum A shall be as close to the head as possible but within 1 P distance of the head. It shall not include the thread run-out or underhead fillet.</p> <p>b MD means that tolerance applies in relation to the axis of the cylinder derived from the major thread diameter according to ISO 1101.</p> <p>c 3×simultaneously</p> <p><b>Figure 95</b></p>	<p>2 IT13</p>	<p>S</p>	

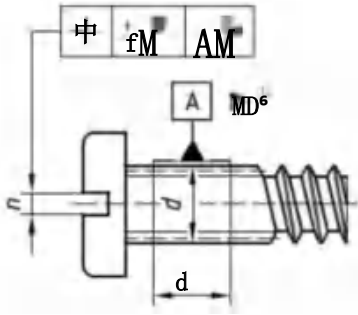
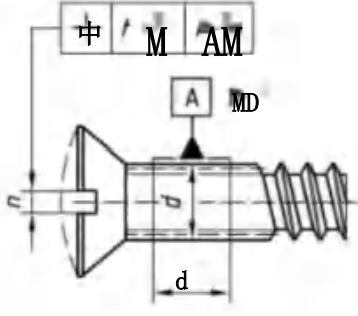
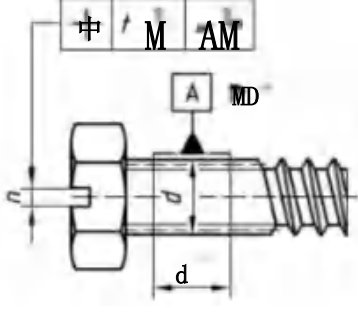
Feature	Tolerance t	Tolerance t based on dimension	Notes
 <p>a, b See Figure 95 Figure 96</p>	2 IT12	d	
 <p>a, b See Figure 95 Figure 97</p>	2 IT12	d	
 <p>a, b See Figure 95 Figure 98</p>	2 IT12	d	

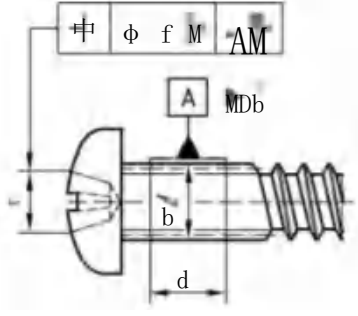
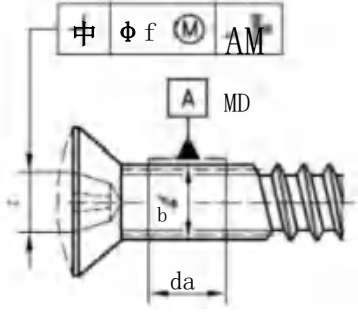
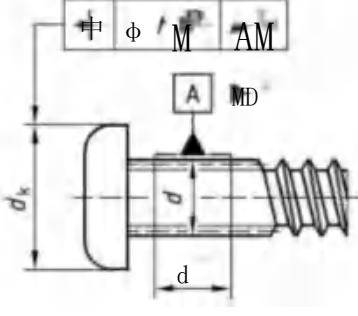
Feature	Tolerance t	Tolerance t based on dimension	Notes
 <p>a, b See Figure 95 c For referee purposes assessment of co-axiality of cross accordance with ISO 4757</p> <p><b>Figure 99</b></p>	2 IT13	d	s recess features shall be by means of a penetration gauge point in
 <p>a, b See Figure 95 c See Figure 99.</p> <p><b>Figure 100</b></p>	2 IT13	d	
<p><b>5.2.2 Other features</b></p> <p><b>5.2.2.1 Tolerance of position</b></p>  <p>a, b See Figure 95</p> <p><b>Figure 101</b></p>	2 IT13	dk	

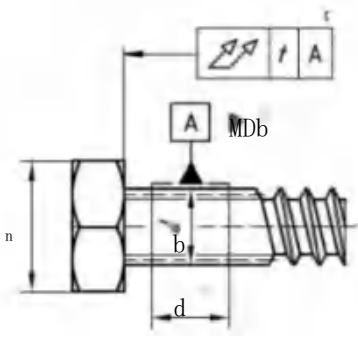
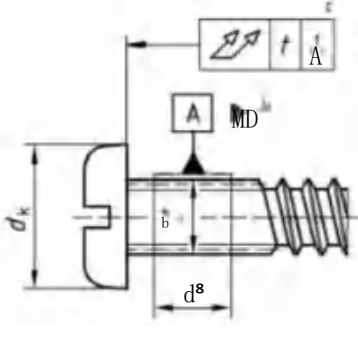
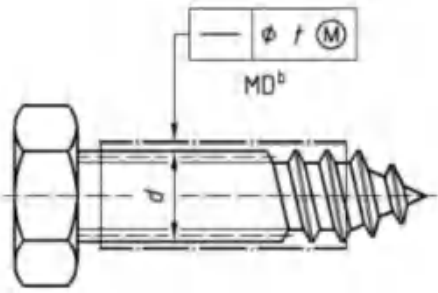
Feature	Tolerance t	Tolerance based on dimension	Notes																				
<p><b>5.2.2.2 Total run-out</b></p>  <p>a, b See Figure 95 c Up to 0,8s diameter only. Figure 102</p>  <p>a, b See Figure 95 C up to 0,8 dk diameter only. Figure 103</p>	<p>d</p> <table border="1" data-bbox="770 963 1010 1299"> <thead> <tr> <th>d</th> <th>t</th> </tr> </thead> <tbody> <tr><td>ST2,2</td><td>0,08</td></tr> <tr><td>ST2,9</td><td>0,16</td></tr> <tr><td>ST3,5</td><td>0,16</td></tr> <tr><td>ST4,2</td><td>0,16</td></tr> <tr><td>ST4,8</td><td>0,3</td></tr> <tr><td>ST5,5</td><td>0,3</td></tr> <tr><td>ST6,3</td><td>0,3</td></tr> <tr><td>ST8</td><td>0,34</td></tr> <tr><td>ST9,5</td><td>0,42</td></tr> </tbody> </table>	d	t	ST2,2	0,08	ST2,9	0,16	ST3,5	0,16	ST4,2	0,16	ST4,8	0,3	ST5,5	0,3	ST6,3	0,3	ST8	0,34	ST9,5	0,42	<p>d</p>	<p>Tolerance t calculated as follows: <math>t \approx 1,2 dx \tan 2</math></p>
d	t																						
ST2,2	0,08																						
ST2,9	0,16																						
ST3,5	0,16																						
ST4,2	0,16																						
ST4,8	0,3																						
ST5,5	0,3																						
ST6,3	0,3																						
ST8	0,34																						
ST9,5	0,42																						
<p><b>5.2.2.3 Straightness</b></p>  <p>b See Figure 95. Figure 104</p>	<p><math>t=0,0031+0,05</math></p>	<p>—</p>	<p>for <math>1 \leq 20d</math></p>																				

## Annex A (informative) Tolerances

Numerical values of IT tolerance grades are given in Table A.1 and the limit deviations for shafts and for holes are given in Tables A.2 and A.3 respectively. These tolerances are taken from ISO 286-1 and ISO 286-2.

**Table A.1—Numerical values of standard tolerance grades IT for basic sizes up to 500 mm**

Nominal dimension >	≤	Standard tolerance grades					
		IT12	IT13	IT14	IT15	IT16	IT17
<b>Tolerances</b>							
	3	0, 1	0, 14	0, 25	0, 4	0, 6	1
3	6	0, 12	0, 18	0, 3	0, 48	0, 75	1, 2
6	10	0, 15	0, 22	0, 36	0, 58	0, 9	1, 5
10	18	0, 18	0, 27	0, 43	0, 7	1, 1	1, 8
18	30	0, 21	0, 33	0, 52	0, 84	1, 3	2, 1
30	50	0, 25	0, 39	0, 62		1, 6	2, 5
50	80	0, 3	0, 46	0, 74	1, 2	1, 9	3
80	120	0, 35	0, 54	0, 87	1, 4	2, 2	3, 5
120	180	0, 4	0, 63	1	1, 6	2, 5	4
180	250	0, 46	0, 72	1, 15	1, 85	2, 9	4, 6
250	315	0, 52	0, 81	1, 3	2, 1	3, 2	5, 2
315	400	0, 57	0, 89	1, 4	2, 3	3, 6	5, 7
400	500	0, 63	0, 97	1, 55	2, 5	4	6, 3

**Table A.2—Limit deviations for shafts**

Nominal dimension >	≤	Limit deviations								
		h13	h14	h15	h16	h17	js14	js15	js16	js17
	3	0 -0, 14	0 -0, 25	0 -0, 4	0 -0, 6	0 -1	±0, 125	±0, 2	±0, 3	±0, 5
3	6	0 -0, 18	0 -0, 3	0 -0, 48	0 -0, 75	0 -1, 2	±0, 15	±0, 24	±0, 375	±0, 6
6	10	0 -0, 22	0 -0, 36	0 -0, 58	0 -0, 9	0 -1, 5	±0, 18	±0, 29	±0, 45	±0, 75
10	18	0 -0, 27	0 -0, 43	0 -0, 7	0 -1, 1	0 -1, 8	±0, 215	±0, 35	±0, 55	±0, 9
18	30	0 -0, 33	0 -0, 52	0 -0, 84	0 -1, 3	0 -2, 1	±0, 26	±0, 42	±0, 65	±1, 05
30	50	0 -0, 39	0 -0, 62	0 -1	0 -1, 6	0 -2, 5	±0, 31	±0, 5	±0, 8	±1, 25
50	80	0 -0, 46	0 -0, 74	0 -1, 2	0 -1, 9	0 -3, 0	±0, 37	±0, 6	±0, 95	±1, 5
80	120	0 -0, 54	0 -0, 87	0 -1, 4	0 -2, 2	0 -3, 5	±0, 435	±0, 7	±1, 1	±1, 75
120	180	0 -0, 63	0 -1	0 -1, 6	0 -2, 5	0 -4	±0, 5	±0, 8	±1, 25	±2
180	250	0 -0, 72	0 -1, 15	0 -1, 85	0 -2, 9	0 -4, 6	±0, 575	±0, 925	±1, 45	±2, 3
250	315	0 -0, 81	0 -1, 3	0 -2, 1	0 -3, 2	0 -5, 2	±0, 65	±1, 05	±1, 6	±2, 6
315	400	0 -0, 89	0 -1, 4	0 -2, 3	0 -3, 6	0 -5, 7	±0, 7	±1, 15	±1, 8	±2, 85
400	500	0 -0, 97	0 -1, 55	0 -2, 5	0 -4	0 -6, 3	±0, 775	±1, 25	±2	±3, 15

**Table A.3—Limit deviations for holes**

Nominal dimension >	Nominal dimension ≤	Limit deviations												
		C13	C14	D9	D10	D11	D12	EF8	H11	E12	H14	H15	JS9	K9
	3	+0,2 +0,06	+0,31 +0,06	+0,045 +0,02	+0,06 +0,02	+0,08 +0,02	+0,12 +0,02	+0,024 +0,01	+0,074 +0,014	+0,114 +0,014	+0,25 0	+0,4 0	±0,0125	0 -0,025
3	6	+0,25 +0,07	+0,37 +0,07	+0,06 +0,03	+0,078 +0,03	+0,105 +0,03	+0,15 +0,03	+0,032 +0,014	+0,095 +0,02	+0,14 +0,02	+0,3 0	+0,48 0	±0,015	0 -0,03
6	10					+0,13 +0,04	+0,19 +0,04	0 +0,018	+0,115 +0,025	+0,175 +0,025	+0,36 0	+0,58 0	±0,018	0 -0,036
10	18						+0,23 +0,05		+0,142 +0,032	+0,212 +0,032	+0,43 0	+0,7 0		
18	30						+0,275 +0,065				+0,52 0	+0,84 0		
30	50						+0,33 +0,08				+0,62 0	+1 0		
50	80						+0,4 +0,1				+0,74 0	+1,2 0		
80	120						+0,47 +0,12				+0,87 0	+1,4 0		
120	180										+1 0	+1,6 0		
180	250										+1,15 0	+1,85 0		
250	315										+1,3 0	+2,1 0		
315	400										14 0	+2,3 0		
400	500										+1,55 0	+2,5 0		

## Annex B (informative)

### Examples of dimensioned and toleranced fasteners

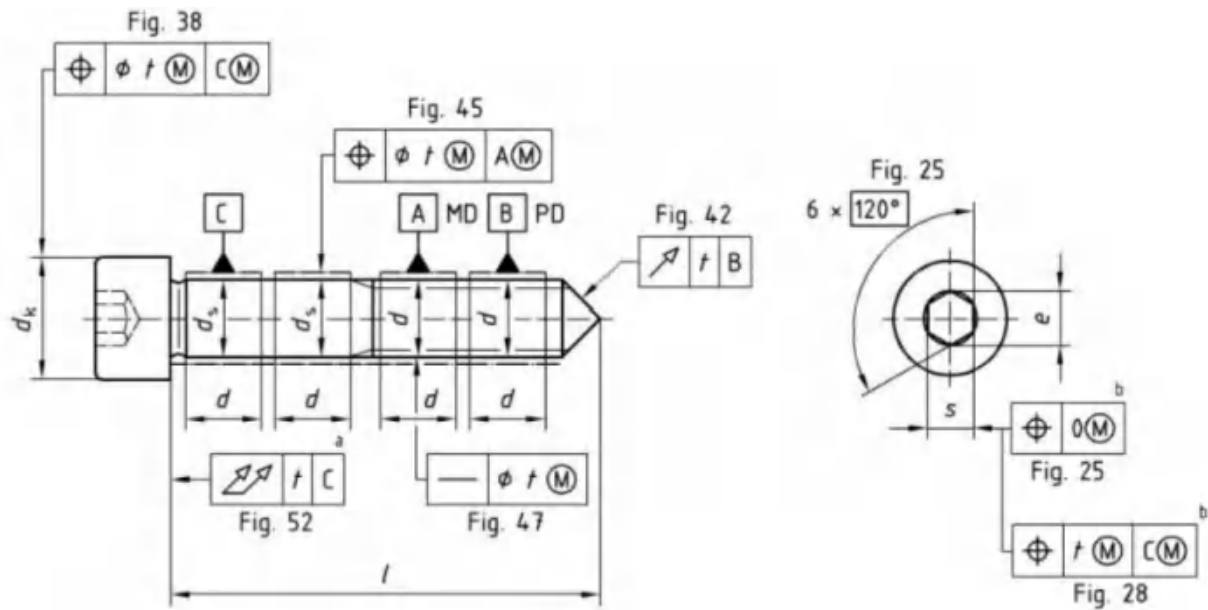

- a Up to 0,8  $d_k$  diameter only.
- b 3×simultaneously.

**Figure B.1—Hexagon socket head cap screw with shank and cone point**

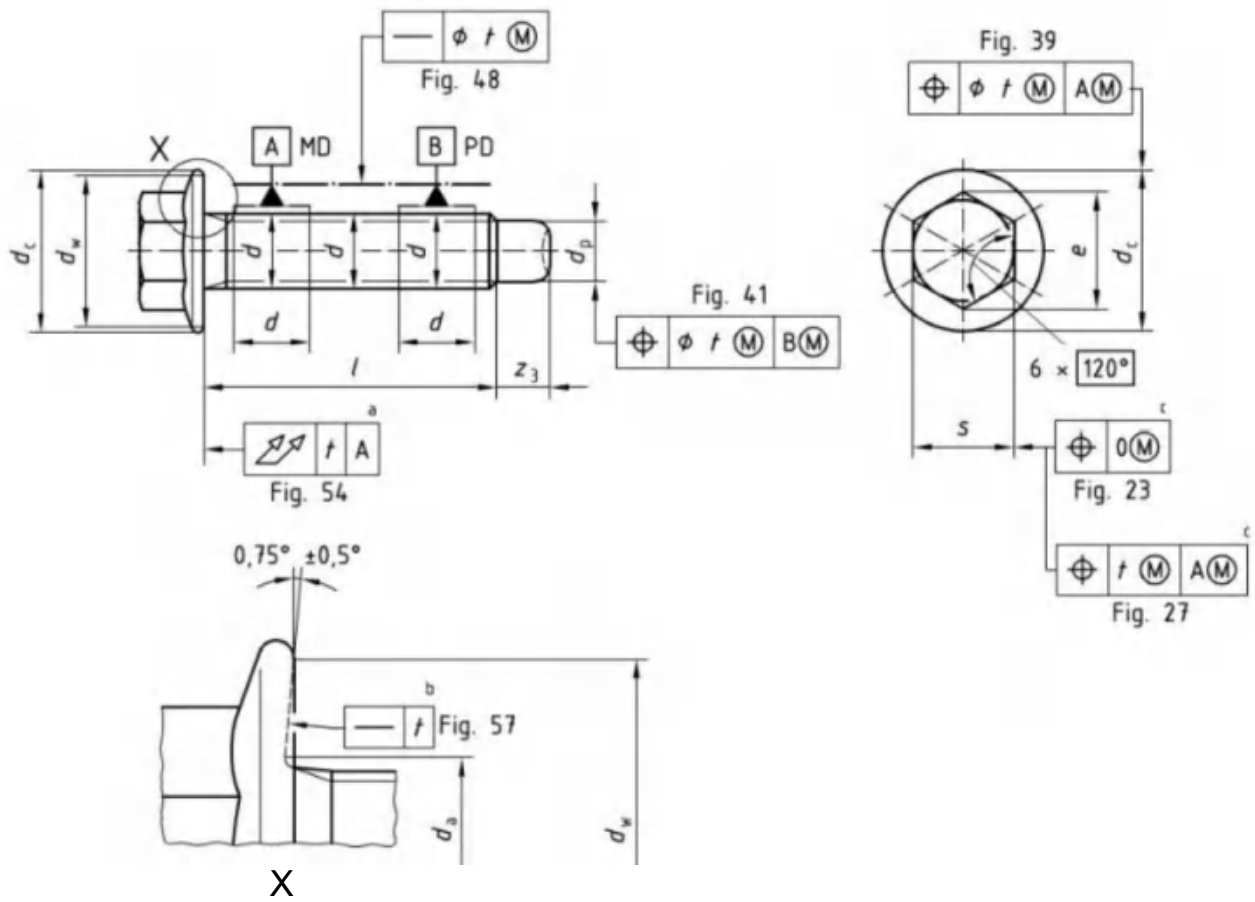

- a Line of highest points on any radial line
- b Radial lines between  $d_{a \max}$  and  $d_{w \min}$
- c 3×simultaneously.

**Figure B.2—Hexagon head bolt with flange and pilot point**

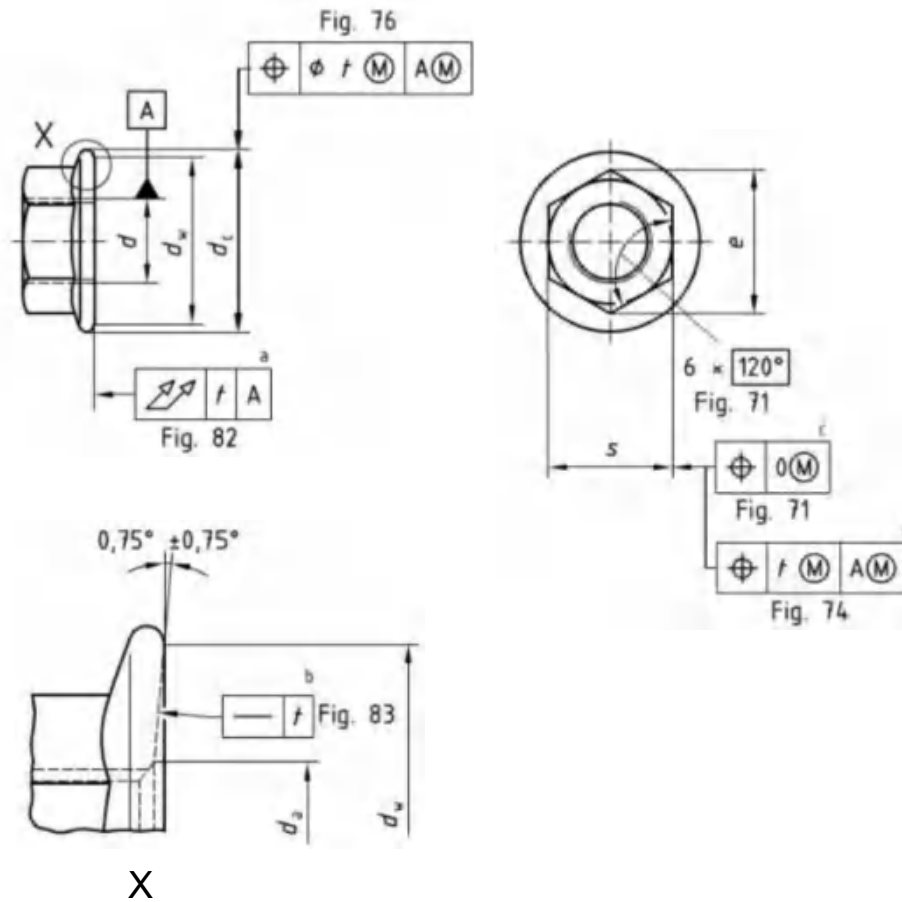

- a Line of highest points on any radial line
- b Radial lines between  $d_{max}$  and  $d_{min}$ .
- c 3×simultaneously

Figure B.3—Hexagon nut with flange

## Annex C (informative)

### Examples of gauges and other measuring devices

#### C.1 Application

This annex gives examples of gauges and other measuring devices which can verify whether the tolerances specified in this part of ISO 4759 are satisfied.

The thread of gauges and measuring devices shall be within the limits for GO gauges. Guides shall have such an accuracy that errors due to the guides during inspection are negligible compared to the workpiece tolerance  $t$  (e.g. less than 10% of  $t$ ).

If the datum is not associated with the maximum material requirements, indicated by  $\text{MMS}$ , the following applies:

when the datum is an external thread, the major diameter axis (MD) or the pitch diameter axis (PD) is the datum as specified in this part of ISO 4759. When the datum is the major diameter, the part may be fixed in a 3 jaw chuck;

when the datum is an internal thread, in the examples of this annex the nut is tightened against a conical spring washer. Another possibility is to use a tapered threaded mandrel for this purpose;

when the datum is a plain shaft or a tapping screw thread it may be fixed in a 3 jaw chuck regardless of the feature size;

#### C.2 Gauges and other measuring devices

**NOTE** All gauges given in this annex are GO gauges. Diameter  $d_g$ , if existent, should be chosen by the gauge manufacturer.

The gauges and measuring devices given in this annex are intended for the verification of geometrical tolerances specified in 3.2, 4.2 and 5.2.

Each gauge and measuring device is allocated to one or more figures in the main body of this part of ISO 4759 in order to make clear which tolerance is verified by which gauge or measuring device.

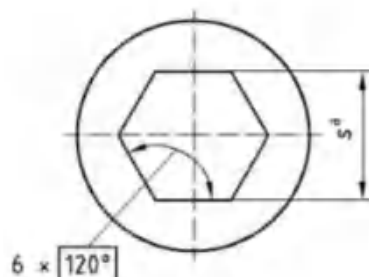

a Maximum material size.

**Figure C.1—Gauge for verifying form tolerance specified in Figures 23,71 and 94**

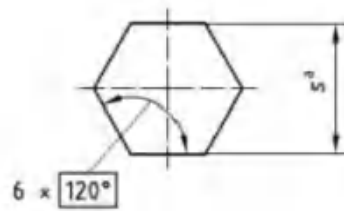

a Maximum material size

**Figure C.2—Gauge for verifying form tolerance specified in figure 25**

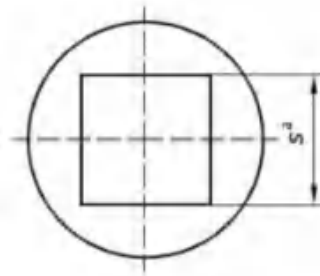

a Maximum material size.

**Figure C.3—Gauge for verifying form tolerance specified in Figures 24 and 72**

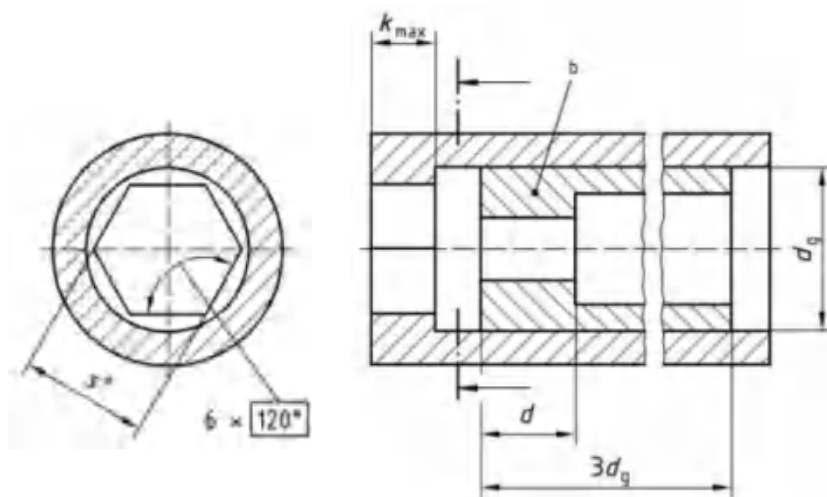

a Maximum material size +t

b The GO gauge is a plain hole of maximum material size

**Figure C.4—Gauge for verifying position tolerance specified in Figures 26,27 and 95**

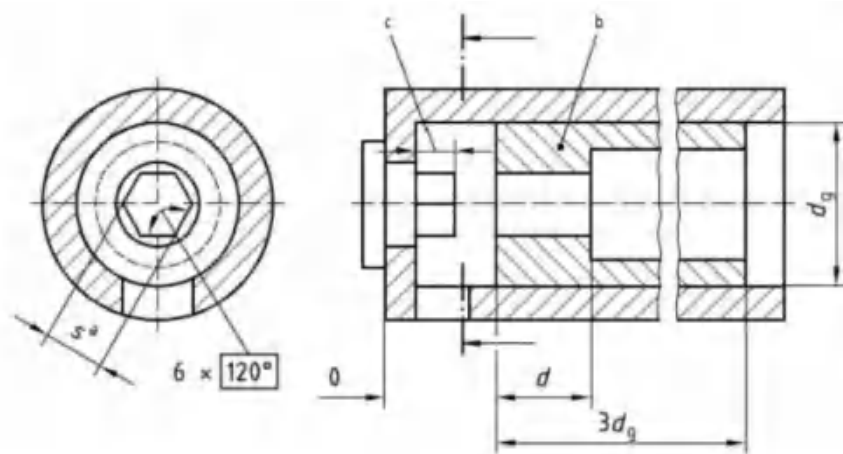

- a Maximum material size-t
- b The GO gauge is a plain hole of maximum material size.  
Minimum socket depth

**Figure C.5—gauge for verifying position tolerance specified in Figures 28,29,30 and 31**

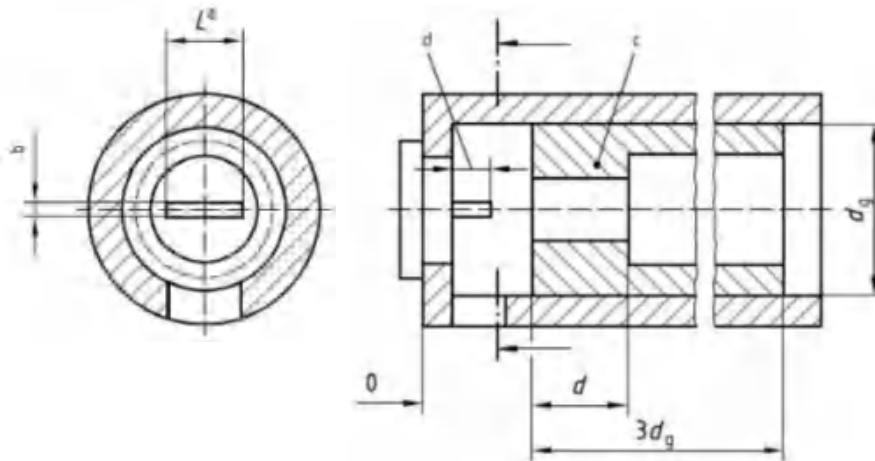

- a  $L > s$  (see Figures 32 and 98);  $L > dk$  (see Figures 33,34,96 and 97);  $L > d$  (see Figure 35).
- b Maximum material size-t
- c The GO gauge is a plain hole of maximum material size.
- d Minimum slot depth

**Figure C.6—Gauge for verifying position tolerance specified in Figures 32,33,34,35,96,97 and 98**

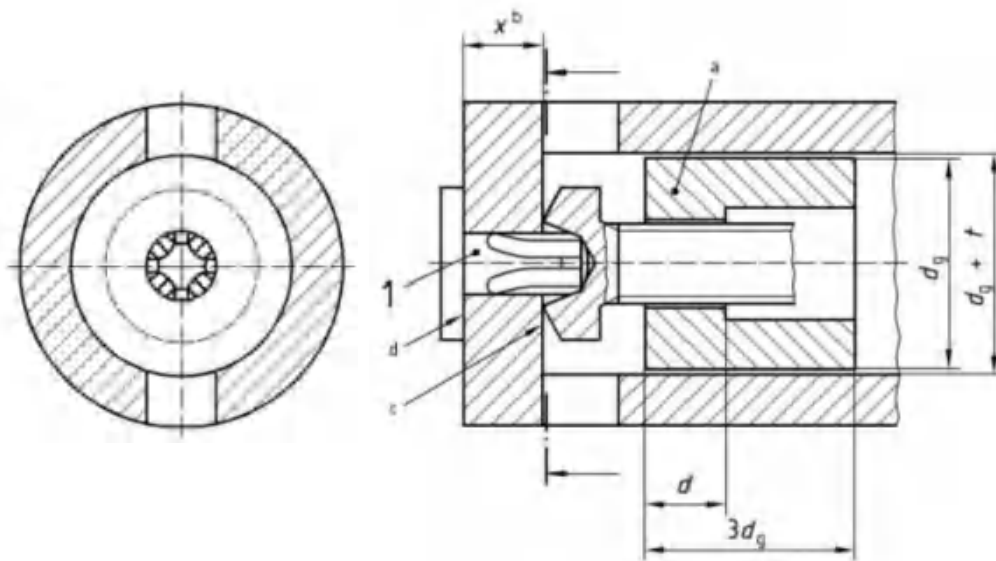

**Key**

1 Gauge pin in accordance with ISO 4757

NOTE This gauge does not check the size of the recess, e.g. an oversized cross recess is not recognized.

a The GO gauge is a plain hole of maximum material size.

b  $x^b$  is a function of length of gauge pin and the required penetration of the recess.

c First contact

d Contact shall be achieved

**Figure C.7—Gauge for verifying position tolerance specified in Figures 36, 37, 99 and 100**

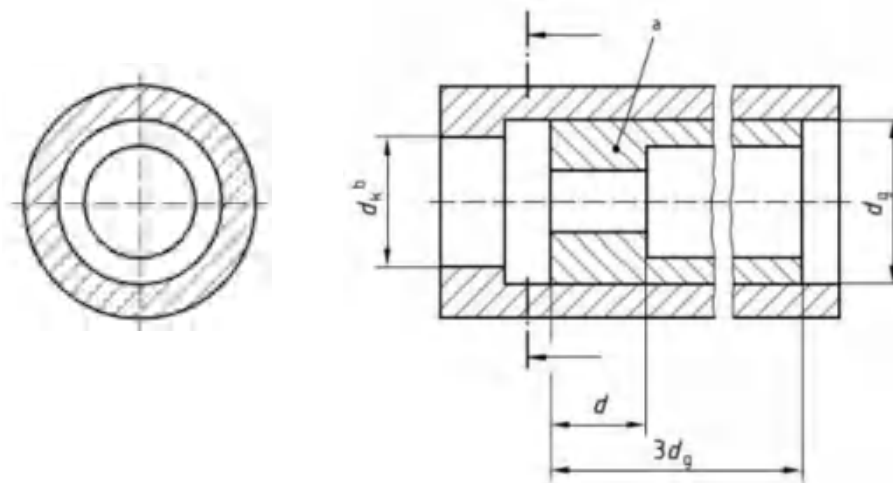

a The GO gauge is a plain hole of maximum material size.

b Maximum material size +  $t$

**Figure C.8—Gauge for verifying position tolerance specified in Figures 38, 39 and 101**

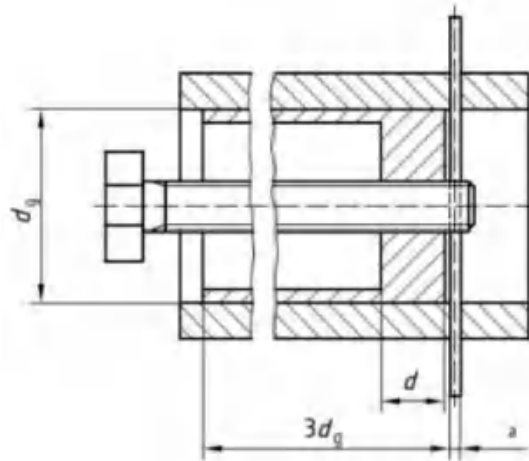

a Maximum material size-t

**Figure C.9—Gauge for verifying position tolerance specified in Figure 40**

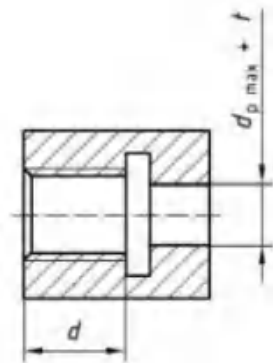

**Figure C.10—Gauge for verifying position tolerance specified in Figure 41**

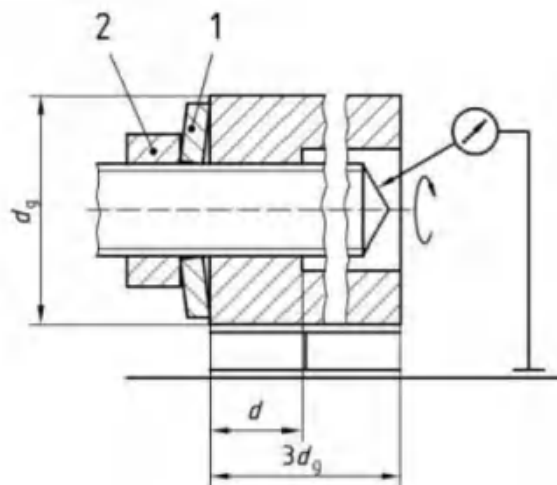

**Key**

1 Gauge conical spring washer

2 Gauge counter nut

**Figure C.11—Measuring device for verifying run-out specified in Figures 42 and 43**

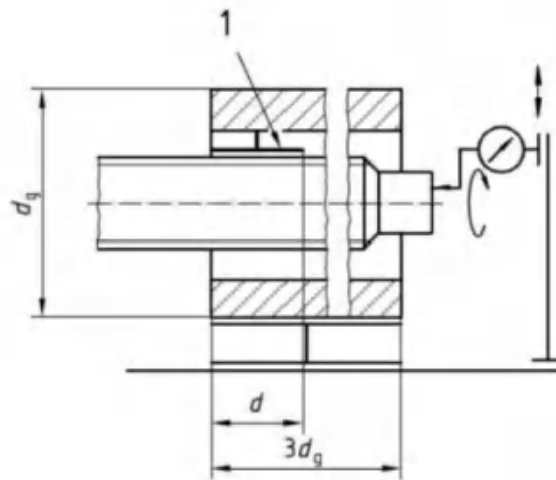

**Key**

1 Three jaw chuck

**Figure C.12—Measuring device for verifying total run-out specified in Figure 56**

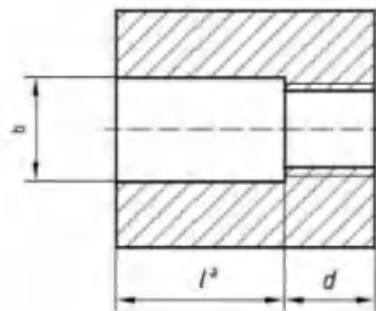

a Depends on the distance between the datum feature and the end of the toleranced feature

b Maximum material size+1.

**Figure C.13—Gauge for verifying position tolerance specified in Figures 44,45 and 46**

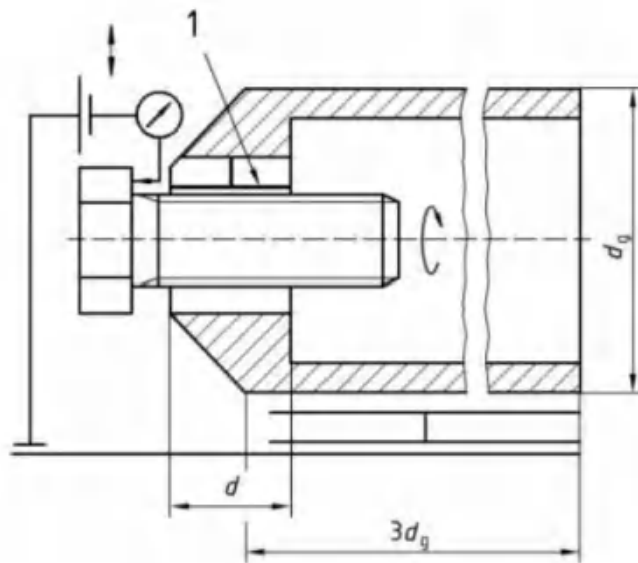

**Key**

- 1 Three jaw chuck

**Figure C.14—measuring device for verifying perpendicularity (total run-out) specified in Figures 51,52,53,55,102 and 103**

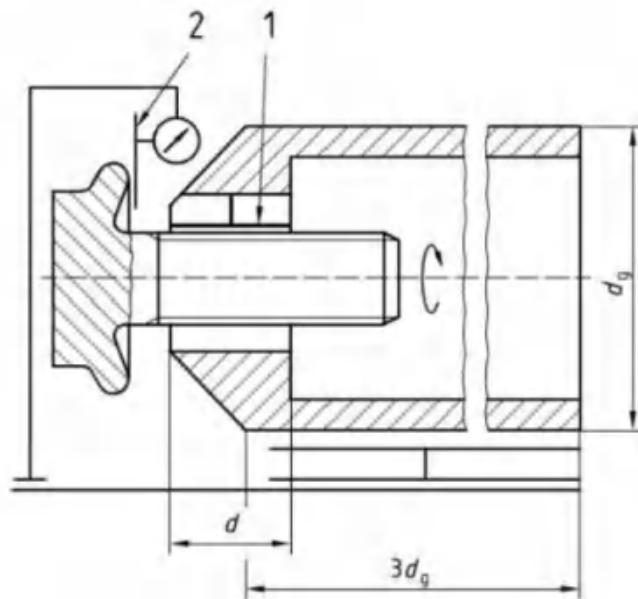

**Key**

- 1 Three jaw chuck
- 2 Straight edge anvil

**Figure C.15—Measuring device for verifying perpendicularity (total run-out) specified in Figure 54**

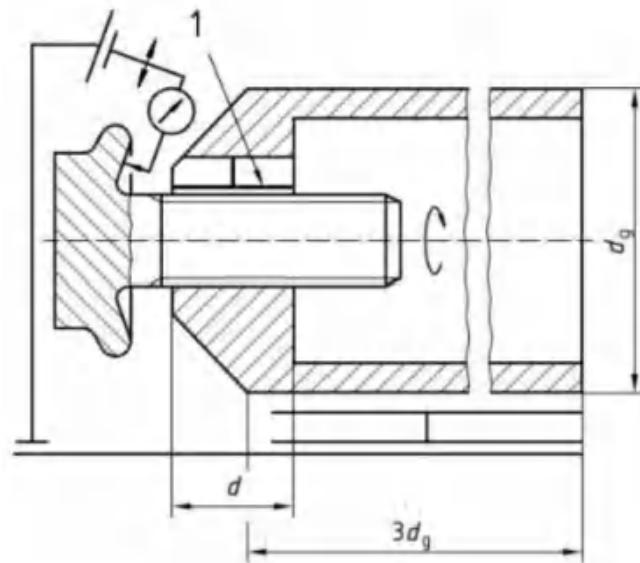

**Key**  
 1 Three jaw chuck

Figure C.16—Measuring device for verifying permissible deviation from the form of bearing face specified in Figure 57

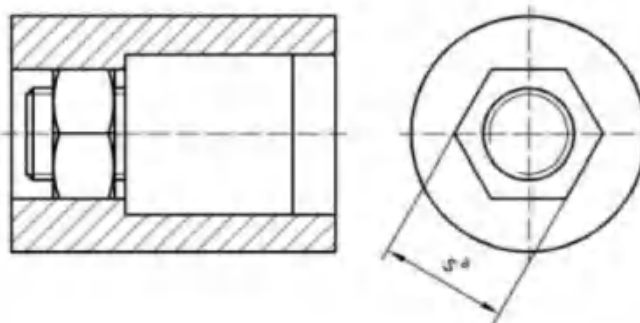

a Maximum material size +1

Figure C.17—Gauge for verifying position tolerance specified in Figures 73 and 74

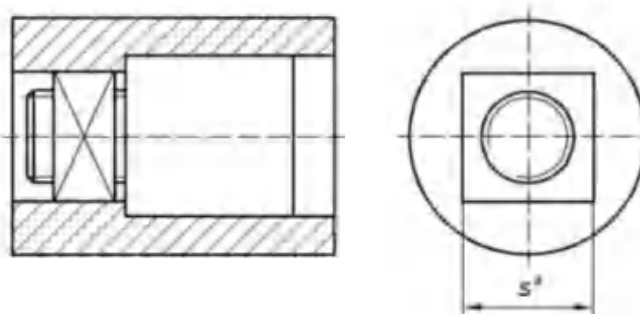

a Max,mat.size+t

Figure C.18—Gauge for verifying position tolerance specified in Figure 75

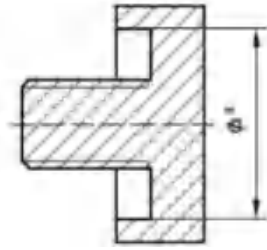

a Max.mat.size +t.

Figure C.19—Gauge for verifying position tolerance specified in Figures 76 and 78

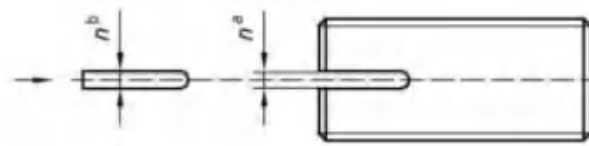

a Max.mat.size

b Max.mat.size-t.

Figure C.20—Gauge for verifying position tolerance specified in Figure 77

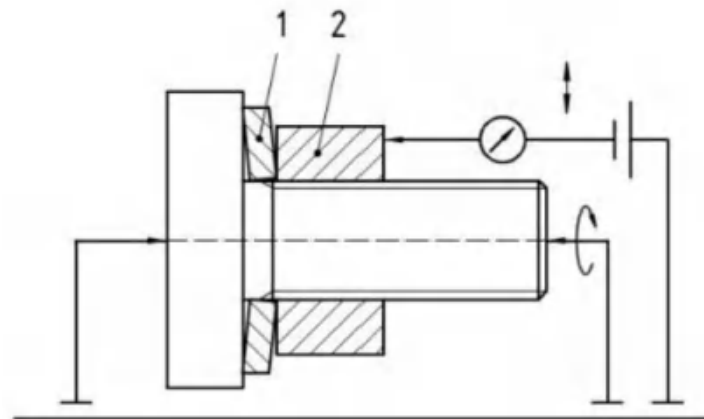

Key

1 Gauge conical spring washer

2 Fastener

Figure C.21—measuring device for verifying perpendicularity (total run-out) specified in Figures 79,80 and 81

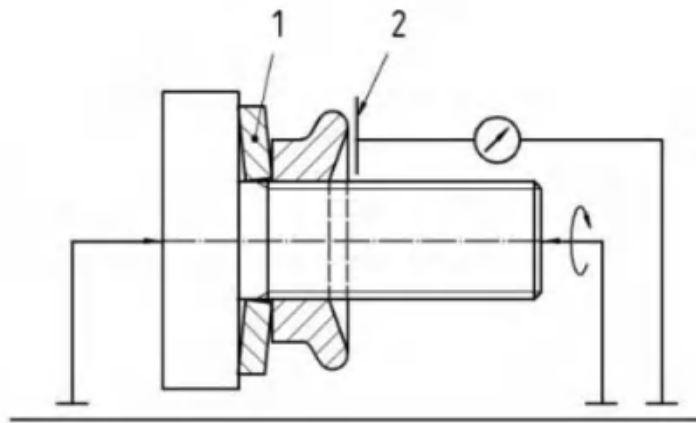

**Key**  
 1 Gauge conical spring washer  
 2 Straight edge anvil

**Figure C.22—Measuring device for verifying perpendicularity (total run-out) specified in Figure 82**

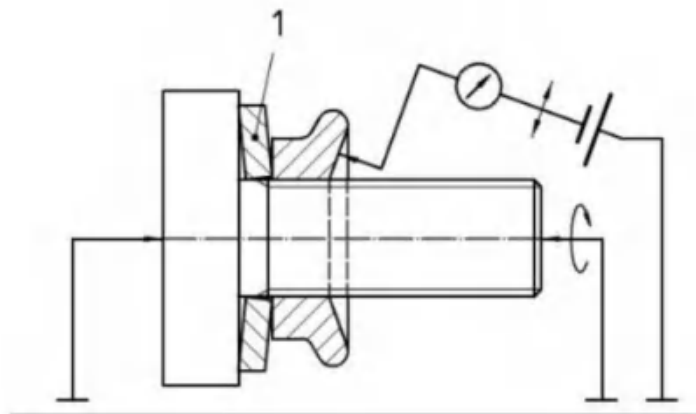

**Key**  
 1 Gauge conical spring washer

**Figure C.23—Measuring device for verifying permissible deviation from the form of bearing face specified in Figure 83**

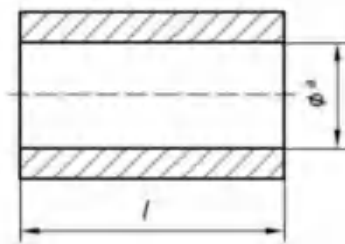

a Maximum material size +t.

**Figure C.24—Gauge for verifying straightness specified in Figures 47, 48, 49, 50 and 104**



---

**ICS 21.060.10;21.060.20**

Price based on 58 pages